

Gazetteer - Baldock to Bletchley

BALDOCK (H)

TL 253 340 & area Zone 7

The area of Walls Field, SE of the present town, is the source of much late Iron Age and Roman material. The site is in a gap in the Chiltern ridge on the route between Braughing and Sandy, so has some importance in communications.

1 Roman burials and domestic rubbish have been known from the Walls Field vicinity since 1925 (Westell 1926; 1931; 1935; 1936; Westell & Applebaum 1933) and now in Letchworth Museum.

2 Pre-Roman evidence was pointed out by Applebaum (Westell & Applebaum 1933, 255); a rouletted buff-ware butt-beaker and a pedestalled cup of G3-3 form, of 'red ware, with black coating', were found together at TL 252 336, on the E side of Walls Field (Westell 1931, 259 and 294, nos.4457-8, Letchworth Mus.). Westell mentions a 'ditch-site' adjoining the Roman cemetery: a piece of a grey butt-beaker copy and some thick coarse storage-jar sherds were known with Roman pieces (Westell and Applebaum *op.cit.*, 255); a thistle brooch is known from the same site (Westell 1935, 349).

A 'very fine ornamented black bowl of Belgic ware, probably made at Treves' was noted by Westell (1936, 364): he apparently means TN. See also Holmes 1958-61, 95.

3 In December 1967 a grave of Stead's early phase of chieftain burials was found on a new housing estate at TL 248 335 (Stead 1968, 306; 1971, for the bucket; Piggott 1971 for the firedogs). A bronze cauldron with rim and ring-handles of iron and containing bones was with a Dressel 1 amphora, two bronze dishes, a wooden bucket with bronze bands and mask handle-mounts, and two iron firedogs. There were apparently no pots.

4 Extensive excavations in the Walls Field area from 1967 have produced much pre-conquest as well as Roman settlement evidence (*Britannia* 1 (1970) 289; 2 (1971), 269; Stead 1975b). As well as much pottery, as yet unpublished, there is some evidence for brooch manufacture in the discovery of two blanks (Stead 1975a, 397). The pottery should prove very interesting for our understanding of the development of local fabrics and forms in the late Iron Age. There are hand-made Iron Age forms in sandy fabrics as well as grog-tempered wares, and some apparent overlap. The forms include distinctively local north Herts.-Beds. vessels. The evidence is of sizeable occupation from the late Iron Age continuing to develop into the Roman period, with numbers of imported wares eventually appearing. Dannell (1977, 232, note 1) mentions early samian.

5:

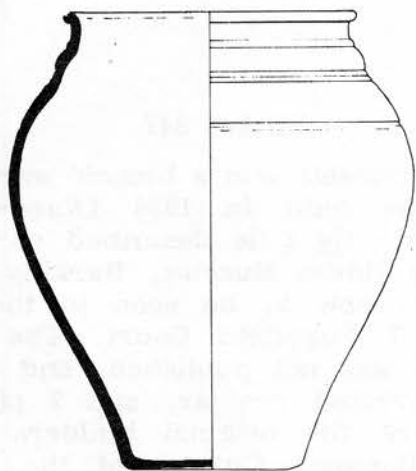

[736] B3-6. LeM 107.1976, from the site of a new RC church; contained bones. Brown-grey, fine grog, pink below grey surfaces, dark grey inside almost all spalled off, patchy brown-grey outside burnished on neck and shoulder & over rim.

BAPCHILD (K)

c.TQ 934 625 Zone 5

Mr Heywood's gravel pit produced 'La Tene III coarse pottery with "soapy surface"', as well as a St Remy ware green glazed jug, a central Gaulish form imported soon after the conquest (Greene's form 2: Greene 1978). They were not, it seems, found together, and there is no more information on the coarse pottery

(C. Hawkes 1930a; Greene 1978, 33). The jug was subsequently stolen from Rochester Museum (Hume 1974, 20, & fig.11).

BARHAM DOWNS (K)

c.TR 210 515 Zone 5

In RM store (8780, 8781) are a number of bags of sherds marked as Bronze Age, Belgic, and Roman. All the sherds are very small and the majority of those marked 'Belgic' are flint-gritted, without forms. There are a few soft red or grey combed sherds that are probably from grog-tempered storage jars; and a piece from an amphora. There are also 3 bronze brooches (not drawn to scale):



8782



8783



8784

BARKING (E)

TL 460 847

'A number of Roman pottery vessels and a brooch' were found when the Longbridge Estate was built in 1934 (Ward-Perkins 1939b). Two pots were published: fig.1 is described as Belgic. The finds were sent to Eastbury House Museum, Barking, which closed in 1940; the fig.1 pot is now to be seen in the office window of Leftley Bros. Ltd., 7 Edgefield Court, The Drive, Barking, with the brooch, which was not published, and a Black Burnished ware pot, a Roman everted rim jar, and 2 pieces of Roman brick. Leftley Bros. were the original builders of the Longbridge Estate. (Mr James Howson, Curator of the Valence House Museum, Dagenham, located the pottery.)

The 'Belgic' pot is, however, Roman, and the 1:4 scale in the published drawing is correct: it is a very large vessel, of elegant form but thick dense lumpy red fabric. It has been restored, with most of the outer surface lost and the inside plastered over. According to Ward-Perkins, it was found behind no.275 Westrow Drive with 'a plain vessel of roughly the same size' in pitted corky ware, which could be compared with Crayford (Ward-Perkins 1938a), fig.4 no.1: a very plain Iron Age form; the 'corky ware' is shell-tempering.

The brooch is a late 1st century AD developed form of the Colchester type, with knobbed foot, triangular pierced catchplate,

a ridge-backed bow, and hooded spring, made in bronze and in very good condition.

BARLING (E)

TL 919 900 Zone 2

A large bowl of the same type as Great Wakering grave 1 nos.1-3, 'found with four little ones, now lost, in a single grave', is noted by Welsford & Rudsdale (n.d.). See type series, form B1-2, for illustration; it is supposed to be in CM but has not been located.

SM has an early Roman vessel with plain everted rim, one shoulder cordon, and a stunted pedestal base: the fabric is brownish-red with hard grey surfaces and many white sandy grits. Now in many pieces. SM 605/1: from Trumpions Farm, TL 922 904, 1939-40 (Pollitt 1953, 67; VCH 1963, 47).

BARMING (K)

TQ 712 544 Zone 4

'A small jar found in Arnold's Quarry in 1931 and further pots found in 1963 and 1966, one containing a cremation' (Kelly 1971, 74, FN 46). Two pots are in MM:

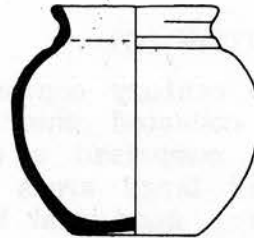

[25] E3-5. 'Arnold's Quarry'. Grey softish fabric, HM, possibly grog, buff surfaces burnished outside.

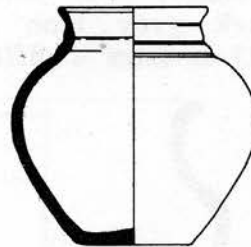

[24] E3-6. 'Nr. Birchwood Cottage'. MM 92.1963. Greensand fabric, dark brown, burnished.

BARNEHURST (K)

TQ 510 757 Zone 3

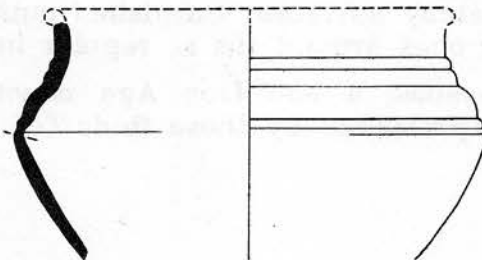

[1009] B3-4. DM 1948.96. Hard grey, grog, dark grey-brown surfaces, burnished outside. Broken at weak point; now only fragments. This was found on Barnehurst Golf Links, immediately N of Crayford.

BARNSTON (E)

c.TL 6520 Zone 1

A 'Cinerary Pot' found 'near Barnston' was published in CMR 1909, 10. The pot, CM 1581.1908, has 'Found in a gravel-pit near Barnston Hall' on its label.

C.J. Going, of Stebbing, informs me that some time ago he spoke to a very old man at Barnston Hall who was present at the discovery of the vessel. Workmen noticed it in the quarry face and he was called to take it out; despite some searching there was no sign of other vessels, and there were no bones inside the pot. There seems no reason to doubt that it was a burial: the bones may have been deposited outside the pot, perhaps in a bag, as at Ardleigh.

For a drawing, see CMR 1929, Pl.II, 2.

B3-5: grey grog-tempered, patchy buff-grey surfaces.

BARRINGTON (C)

c.TL 4050 Zone 9

19th century coprolite digging in this parish produced many objects, collected chiefly by the Rev. J.W.E. Conybeare. His collection comprised a great range of objects found over many years and large areas of the parish. Conybeare (1903, 434-9) describes a good deal but not coarse pottery. CambM has much Romano-British material (1907.798-9), and some earlier things: La Tene I brooches; a bronze Colchester brooch with fretted catchplate; a small dark grey cup (1913.113, of E1-1 shape but straight-sided) in a sandy fabric; and the body of a finely combed thick dark grey Iron Age jar, 1913.201. The bowl (Fox 1923 Pl.XII, 4) is from a different collection, the Foster Bequest.

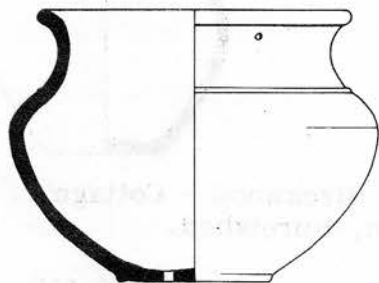

[909] D1-2. Z.11517, W.K. Foster Bequest, 1891. Sandy, but from wear and drilled holes may have some grog. Restored; grey-brown patchy surfaces, burnished outside. 3 holes drilled in base; 3 smaller ones around rim at regular intervals.

We may assume a late Iron Age cemetery, or at least one burial, to be represented by these finds (cf. Fox 1923, 109-110).

BAYNTON END (E)

Lindsay (1958, 200) states that 'a small amount of pottery with fragments of wattle-and-daub marking a (?)Belgic farmstead' was found here near Wixoe. The sherds were apparently kept by the finder, and without some corroboration it would not be wise to accept this description, from an uncritical source. At Wixoe there is a Boynton End (TL 720 443) and a Baythorn End (TL 725 428) but not, it seems, a 'Baynton End'.

BEDFORD (B)

TL 0580 4826 (London Road) Zone 7

1 BedM has 5 pots found in 1926-27, in London Road. No associations were recorded. The vessels are illustrated in Simco 1973, fig.7:

57 a large sandy jar, flat base, rim lost: probably Roman.

58 E3-7. Fine gritty black ware with dark orange surfaces.

59 E3-7. Black core, buff surfaces, possibly grog-tempered.

60 E1-3. Probably gritty grog-tempered.

61 plain butt-beaker, grey, not grog-tempered.

BedM 3705. The E3-7 type is a local form, and these seem to be local fabrics.

2 BedM also has two unprovenanced vessels:

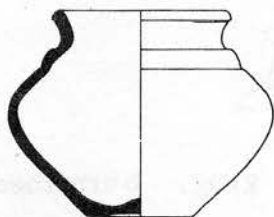

[743] E3-5. BedM 121. Grey, grog, worn buff surfaces, irregular.

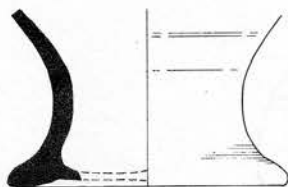

[1159] A1. Unmarked. Dark grey, grog, brown-grey surfaces, pale burnish outside.

See also NEWNHAM.

BERKHAMSTED (H)

SP 985 089 (Dellfield) Zone 7

SP 958 102 (Cow Roast)

1. Construction work on the site of a new school at Billet Lane, Dellfield, in 1971-2 found good evidence of late Iron Age occupation (Thompson & Holland 1974-76). Emergency excavation by local groups found much of the site damaged by terracing, but discovered 4 pre-conquest burials, two pre-conquest ditches and one medieval, and at least 4 shaft furnaces for iron of early post-conquest date.

Apart from iron nodules the only metal objects came from the burials.

Most of the pottery is in VerM, and is almost invariably grog-tempered apart from white ware butt-beaker fragments, Roman flagons, and a few Roman coarse ware pieces. Included in the type series are:

<u>Ditch A:</u>	1: B3-2	26: B1-1
	2: C6-1	27: D1-1
	3: B1-4	29: D1-1
	4: B1-4	30: B1-1
	6: B3-2	31: C5-1
	10: C6-1	32: G2-5
	11: C1-2	34: C7-1
	13: C1-2	36: C1-2
	15: B1-1	37: C1-2
	20: E3-1	38: C1-2

Nos. 18, 19, 24, and probably 35 are post-conquest.

Ditch B: 40: C7-1 44: B1-4

This ditch otherwise included several pieces of white or buff butt-beakers, and the ring neck of a post-conquest flagon.

I have also included a few unpublished vessels from those in the Museum:

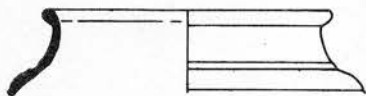

[110] B3-1. Buff, much grog, burnished dark grey outside, worn to orange on inside.

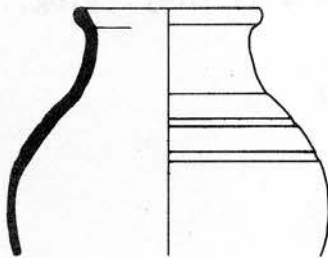

[109] B3-8. Buff, much grog, burnished dark grey-brown surfaces, worn inside.

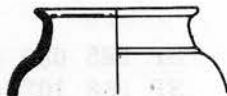

[111] E3-1. Pale grey, grog, burnished dark brown outside, worn; worn brown inside.

The burials: all the pots from burials 1 and 2 are at the Bridgewater School now built on the site. I have not seen them but they are unlikely to be other than grog-tempered.

Burial 1: 57: C2-1 59: B4-1, very rare, and not early.
 58: E1-4 60: A8

With these were an iron disc and a whetstone.

Burial 2: 61: D2-2 63: E3-2
 62: B1-3 64: B4-2, a late form.

With an iron brooch with 4-coil spring, internal cord, and solid catchplate, of uncertain date but usually pre-conquest. Also an indeterminate piece of bronze.

Burial 3: 65: B3-6. In VerM, pale brown-red grog, patchy and worn. 'The remains of two other pots showed that this group had consisted of at least three pots'.

Burial 4: 66: C7-1, a scrap only. Brown, grog, pale orange surfaces. With 'part of an iron band... with 4 thicker strengthening bars. Possibly the upper supporting band of a wooden bucket'; with some bone fragments. The burial was too much destroyed to be better defined.

The furnaces: no.79: C7-2, grog-tempered, found in the tapping pit of furnace 3. Other scraps were also found, in furnace 2. The furnaces themselves were dated to the later 1st century AD on technical grounds, and these scraps are essentially unstratified.

2. Excavations on the site of the Roman settlement at Cow Roast have found two ditches containing Iron Age pottery (Britannia 7 (1976), 338; Orna 1975).

BETHERSDEN (K)

TQ 909 421 'Tuesnoad' Zone 5

VCH (1932, 146) reports 'a black saucer and rough pottery from Tuesroad Farm, 2 miles NW of Bethersden... in the Maidstone Museum'. These were found in 1860; the 'rough pottery' is not now traceable.



[964] G1-8. No number. Not regular, and possibly even HM; badly restored, dark grey, signs of possible grog on inside base.

BEXLEY (K)

TQ 5063 7344 Zone 3

A ditched farmstead site, at Cold Blow, close to Stone and Crayford, in west Kent (Caiger 1958). The pottery is in Dartford Museum, DM 1959.226. A short length of ditch, with traces of a smaller ditch at a distance, were excavated in the garden of a new house on a housing estate. No other evidence seems to have been reported from the estate. The fill of the larger ditch was rubbish thrown in over the primary silt; it included animal bones, part of a quern, an iron knife, and a possible triangular loomweight, and pottery of mixed style and date. Much of this was evidently shell-tempered and similar to Crayford (q.v.).

The illustrated vessels are as follows:

1,2 shelly, storage jars.

- 3 Roman, grey, storage jar.
- 4 TN platter, form Cam.1 but deep.
- 5 neatly made, grey-brown, some grits and perhaps some grog. Not such a prominent rim as in the drawing, and only one cordon, formed by two tooling lines.
- 6 brown pitted ware, like some Crayford jars; red grits, neatly finished and burnished. No grog.
- 7 D1-1. Fine grey grog-tempered fabric, fine pale orange soapy surfaces, horizontal tooling on neck. Like Patch Grove ware, i.e. grog-tempered wares that last well into the 2nd century in Kent.
- 8 B5-5. Coarse lumpy brown grog-tempered, now very brittle; once had a dark brown outer surface, now worn to red.
- 9 B5-1. Hard thick dark grey-brown, probably some grog, grey inside, burnished dark grey outside. Neat bead rim. Like other sites west of the Medway, Bexley has a very mixed collection of pottery, and grog is by no means predominant. Some of the pieces are late and even Roman; the platter should indicate a degree of prosperity. It is unfortunate that only a 20ft length of ditch was excavated, since as it stands we know little about the site.

BIDDENHAM (B)

c.TL 0250

Hawkes & Dunning (1930, 325) mention a pedestal urn kept at Bedford Modern School. This vessel is now in BedM, and published with three others and described as 'of inexact provenance' by Simco (1973, fig.6, nos.51-54). These are late 1st century Roman vessels.

BIERTON (Bu)

SP 836 153 Zone 7

Excavations in 1979 in the area of the church in advance of development have revealed Iron Age, Roman, and medieval occupation (*Britannia* 11 (1980), 373). The Iron Age evidence is of round houses and a ditch complex, with hand- and wheel-made pottery, and brooches. The interim report (D. Allen 1979) illustrates an early Roman coarse jar, a carinated cup of E1-1 form, a bronze straight-bow Colchester brooch, and a late potin coin.

BIGBERRY (K)

TR 117 575 Zone 5

Whatever the date of any 'Belgic' pottery here, this is still likely to be 'the place in the woods defended by art and nature' that Caesar stormed in 54 BC (Jenkins 1962, 9). The hill fort seems to be the predecessor of the late Iron Age and Roman settlement of Canterbury, a sequence to be found elsewhere (Wilbury Hill and Baldock; Gatesbury and Braughing).

A variety of finds on the site were made in the 19th century, summarised by Jessup (1932). Excavations in 1933-34 (Jessup and Cook 1936) were on a site already much damaged by building and quarrying, and only the defences were closely examined. These are well described and summarised by Champion (1976, 115-6).

Jessup (1932) describes the various collections of ironwork found on the site, in particular in quarry pits, in the previous century. A good deal of what Jessup thought of as pre-conquest is Roman, but the 'slave-chain' and firedog are relevant here (see Piggott 1971). The pottery in Jessup's fig.4, in MM, is all of hard Roman fabrics; nos.2 & 3 are jugs, and no.1, the closest in form to a 'Belgic' type (D1-4) is hard and red, in fabric quite unlike the grog-tempered version.

The pottery from the excavations is in MM, together with some found in 1887. It is not true that 'there is nothing in the assemblage that must belong to the Aylesford-Swarling tradition' (Champion 1976). The pottery shows the overlap of traditions that is evident from other sites in Kent. Nearly all of it is HM with flint grit tempering, sometimes well finished; but it does include a grog-tempered storage-jar rim of C6-1 form (Jessup & Cook 1936, fig.6 no.90 - the scale is 1:2, not 1:4 as indicated). The piece is distorted too much to be sure of the rim diameter; it is coarse, grey, cracked, and worn.

The pedestal base, fig.6 no.81, is finely gritted, HM, with a dark grey core and orange-buff surfaces, smoothly finished. The A5 type is almost unknown in Kent, and I would hesitate to consider this a copy of a grog-tempered form.

Pottery found in 1887 and now in MM includes a few grog-tempered sherds, without definable form but including a piece from the curving neck of a jar, grey with orange surfaces. Two pieces with curvilinear stamped and rouletted decoration are also present, in a brown fabric full of small white grits. It is noticeable that the flint-gritted sherds from this group are very much overfired.

A small collection of pottery from the site now in RM (6927; 1950. 120.3), from F. Jenkins, comprises a few flint-gritted rim scraps, a coarse grey storage-jar rim, probably grog-tempered, with reddish burnt surfaces, a HM flint-gritted base of A7 form, and a similar but grog-tempered base:



[1547] A7. RM 6927. HM, grey grog, reddish outside, tooled on all surfaces but worn.

The 'occupation layer' from which the published storage-jar rim no.90 came, with HM gritted forms, 'underlay the rampart and extended for an indeterminate distance into the interior of the Camp' (Jessup & Cook 1936, 153). Recent work will when published provide new sections of the northern defences and the annexe; within the earthwork were a cross-ridge dyke and a water-hole (F.H. Thompson 1978a, b; 1979a, b; 1980). The pottery, which Mr. Thompson kindly allowed me to examine, is of a similar mixture to that previously found: a large quantity of flint-gritted pieces of various Iron Age forms, with a few grog-tempered. There is no mixture of tempering within the same vessel, as at some Kent sites; there is some greensand, but not in 'Belgic' forms. Nor are there any 'Belgic' forms in flint-gritting. Pieces of the same pots (not grog-tempered) were scattered in

various features. The most substantial grog-tempered sherds came from the waterhole fill, with a quantity of good flint-gritted forms. A Dressel 1 amphora handle, found in the spoil, may have come from the waterhole also. A B3-1 cordoned jar rim, a HM storage-jar rim of anomalous form, and combed sherds from a storage-jar were the only discernible grog-tempered forms from the excavations. None of these provides much indication of date, although the cordoned jar is well made and sharply defined.

It is apparent that grog-tempering was never standard at Bigberry. Full publication of the recent excavations, with radiocarbon dates and modern assessment of the pottery, should provide interesting information on the spread of this fabric in Kent.

BIGGLESWADE (B)

c.TL 207 437 Zone 7

The area has produced a concentration of 'Belgic' coins, notably the early silver and bronze Lx coins (D.F. Allen 1961, 124; 1962, map 3; and Haselgrove 1978, 35, for additions).

BedM has an early Roman cremation urn from Biggleswade (BedM 86), a biconical jar with multiple cordoned neck, and containing bones; it is not grog-tempered. There is no late pre-Roman evidence yet other than the coins.

BILLERICAY (E)

TQ 681 953 (Norsey Wood) Zone 1/2

TQ 677 936 (school)

There is considerable evidence of late Iron Age and Roman settlement here on a ridge overlooking lower ground sloping gently to Mucking and the Thames crossing; but much of this evidence is from collections of pottery made in the mid-19th century, for which all associations have been lost.

Roberts (1859-63) shows sketches of Roman pottery, chiefly from the Union House and the Dissenters' burial ground, and quotes Morant's record of pottery found in 1724; many coins were also known. Morant is also quoted by Sparvel Bayly (1879) who relates that many vessels were found in Norsey Wood 'about 80 years since' and probably destroyed in the burning of Thorndon Hall. The 1860s saw the discovery of many burials:

a number of urns found in widening the Chelmsford road near the Union House;

many articles found by Major Spitty in the field near the Union House;

Roman burials and a pit near the mill;

burials found in Norsey Wood, 'at the end nearest Billericay': these consisted of pots 'mostly in groups of two or three; only one in each group contained bones... one urn contained bones, ashes, and a bronze fibula'.

Sparvel Bayly makes it clear that a great deal of Roman material in particular was being discovered in and around the town, and many local people were making collections.

The Norsey Wood cemetery was discovered in gravel digging; pits, a kiln, ditches containing pottery and tiles, and two tumuli of apparently Roman date are described by Branfill (1895). A plan

of the wood is given by Kimball (1938) who excavated a section through the bank and a strip behind it, at the SW corner near the site of the 1860s discoveries. The bank, known as the Deerbank, is a medieval park boundary and not Iron Age, as far as is known.

A few earlier Iron Age sherds were found at Site A, but the trench dug by Kimball behind the bank, and not related to the bank itself (Kimball *op.cit.* pl.16, nos.1, 2). Pottery described as Iron Age, Belgic, and Roman, including 4 reconstructable vessels were found in a 'pit' at Site C in the area of the gravel pits inside the wood, and half cut away by quarrying. The four pots nos.9-12 are post-conquest: 9 is a Roman jar and 10-12 are shelly jars made in SE Essex in the conquest period, often bearing 'graffiti' on the shoulder, as does no.10 here (Jones 1972). These are now in CM 112.52.

The 'Iron Age' sherds nos.3-8 were mingled with the other pieces from Site C, nos.9-24; most of them, if not all, appear to be coarse vessels including shell-tempered with slashing on the surface etc. of post-conquest date. All the Site C sherds might be post-conquest, although some 'Belgic' forms are evident in Kimball fig.4; they should be in CM but have not been found.

No.13: B3-1

No.17: S5

No.16: G3-4

No.18: B2-1

Nos.9, 14, and probably 15 are Roman. No.19 is HM and flint gritted. Sherds, a loomweight, and a glass bead of the 1st century AD and later (Branfill 1895, 235) are in ChM (B18513).

The real evidence for pre-conquest settlement comes from the burial pots collected in the 19th century, of which a selection found their way into CM (CM 1616.1908, Spitty Coll.). Some are fine vessels; another indication of some wealth was the remains of a mirror (Fox 1958, fig.61; Toynebee 1964, 18-20; cf. Spratlin 1970).

[1145] A3 (=AB 179). Originally a fine pot, now very badly restored. Grey, grog, buff patchy outside, inside obscured with plaster and bandages. Neatly burnished; clear decoration done with burnishing tool, not incised.

[996] A3 (=AB 200; not 1668.08). Grey-brown hard grog; reddish below red-grey surfaces, smooth outside. Foot restored. Possibly romanised like [994] below.

[828] B5-3 (=AB 199). Grey grog, buff-grey patchy surfaces, some tooling outside; restored, inside a bit obscured. Quite well made but worn.

[1092] F2 (=AB 219). Leans slightly but was once a fine vessel; badly burned, and restored. Probably made with a template: strong precisely detailed cordons. Grey, grog, buff inside, burnt grey-green outside, some crackling and remains of fine burnish. Contains bones.

[957] F2 (=AB 220). 'Dug up near Billericay by TJS Jun 9th 1860.' Once a fine pot, badly restored. Grey, grog, buff showing inside; brown-grey burnished outside.

[794] B3-4 (=AB 202). 'Dug up near Billericay May 1860.' Rim shattered. Grey-brown, grog, red below reddish inside.

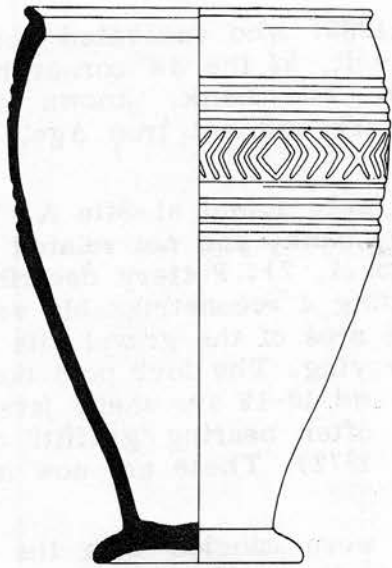

[1145]

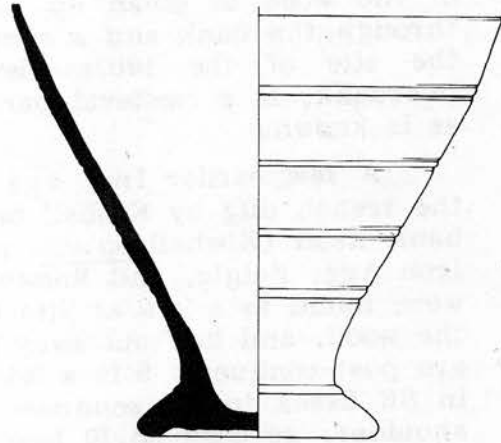

[996]

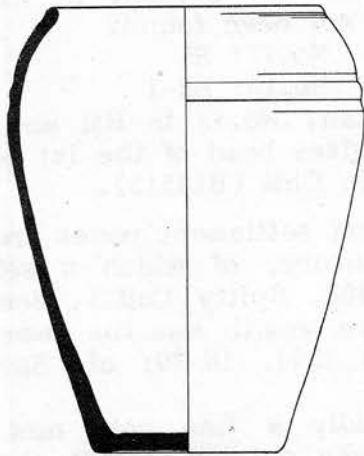

[828]

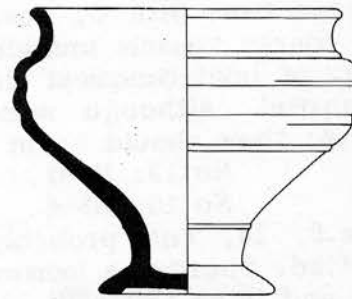

[1092]

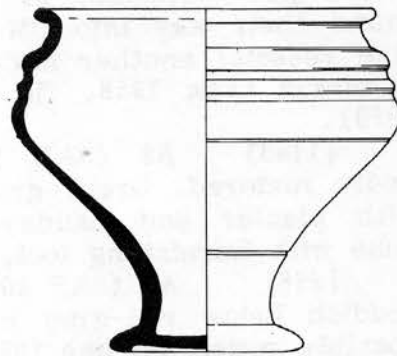

[957]

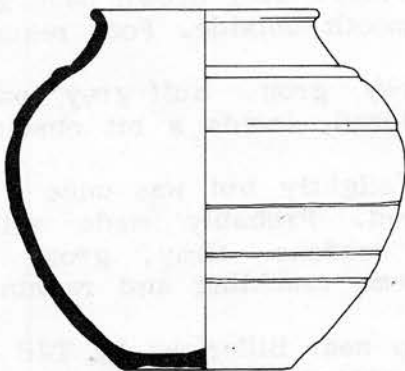

[794]

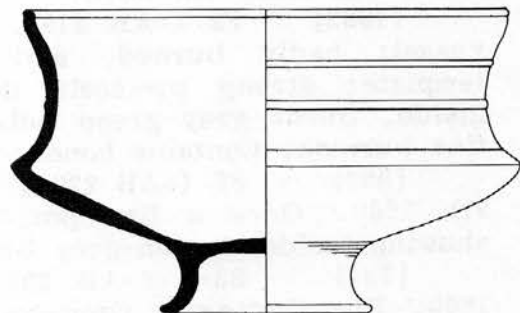

[793]

Fig.10a: Pottery from Billericay. 1:4

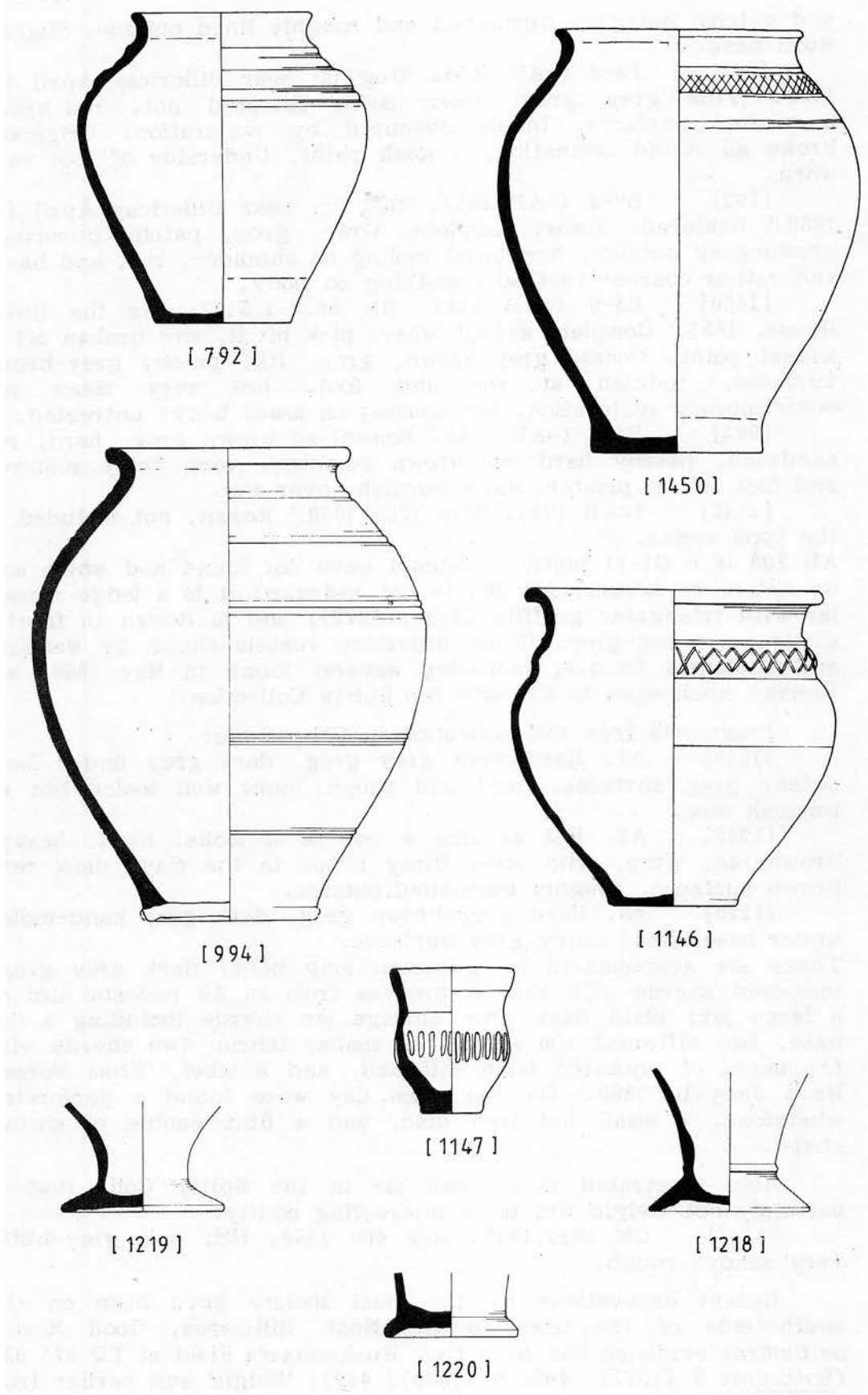

Fig.10b: Pottery from Billericay. 1:4

and patchy red-grey burnished and roughly lined outside. Slightly worn base.

[793] F3-4 (=AB 166). 'Dug up near Billericay April 4th 1860.' Fine grey grog, worn much restored pot, red-brown burnished surfaces. Inside obscured by restoration. Originally broke all round carination, a weak point. Underside of foot very worn.

[792] B2-3 (=AB 165). 'Dug up near Billericay April 4th 1860.' Restored, almost complete. Grey, grog, patchy burnished brown-grey outside, horizontal tooling on shoulder, rim, and base, and rather coarser vertical smoothing on body.

[1450] B3-6 (=AB 113). BM 56/7-1/5117; 'Nr the Union House, 1851.' Complete except where pick hit it, and broken off at widest point. Coarse grey-brown, grog, HM, patchy grey-brown surfaces, reddish at rim and foot. Not very clean and contemporary restoration. Not combed on lower body: untreated.

[994] B3-7 (=AB 178). Romanised brown grog, hard, red sandwich, patchy hard red-brown surfaces, very badly restored and foot full of plaster. Some burnish, over rim.

[1146] (=AB 192). 'May 17th 1860.' Roman, not included in the type series.

AB 203 is a G1-11 platter, which I have not found and which may be native or Roman. AB 201 is not redrawn: it is a ledge-rimmed jar with triangular graffito (Jones 1972), and is Roman in fabric, gritty, and red-grey. Other Billericay vessels shown by Welsford and Rudsdale (n.d.), including several found in May 1860, are Roman; much came to CM with the Spitty Collection.

Fragments from this collection in CM include:

[1219] A1. Hard dark grey grog, dark grey under foot, patchy grey surfaces, hard and rough; once well tooled but no burnish now.

[1218] A2. Not as fine a pot as it looks: hard, heavy, brown-red, grog, with some flinty lumps in the clay, dark red-brown surfaces, roughly burnished outside.

[1220] A6. Hard grey-brown grog, dark grey hand-tooled under base, hard sandy grey surfaces.

These are accompanied by a human long bone; dark grey grog-tempered sherds with shallow grooves from an A3 pedestal urn or a large jar; plain dark grey storage jar sherds including a flat base, two different rim sherds of similar fabric, two sherds with fragments of cremated bone attached, and a label, 'From Norsey Wood Jany.10 1868.' On the same day were found a perforated whetstone, a small flat iron disc, and a flint pebble of similar shape.

Also illustrated is a small jar in the Spitty Coll. that is certainly not 'Belgic' but is an interesting oddity:

[1147] CM 1616.1908. May 4th 1860. HM, pale grey-buff, very sandy, rough.

Recent excavations by the local society have been on the south side of the town in the Noak Hill area. Good Roman settlement evidence has come from Buckenham's Field at TQ 675 934 (*Britannia* 8 (1977), 405; 9 (1978), 449); 'Belgic' and earlier Iron Age pottery has come from the school site in particular, and a

second mirror handle 'similar to the "Mayer" example and Belgic pottery' have come from the Noak Hill roadworks at TQ 6759 9344, with Roman burials (Weller 1974, 282).

BIRCHINGTON (K)

TR 285 696 (Minnis) Zone 5

TR 307 697 (Epple)

This Isle of Thanet town has a wide range of interesting material kept in the Powell-Cotton Museum at Quex Park, Birchington.

1 The Park itself produced a hoard of over 600 Class I potin coins in 1853, most of which are in the museum: TR 310 683 (D.F. Allen 1961, 204; Barrett 1893, 3).

2 Minnis Bay: erosion of the chalk cliffs on the foreshore has revealed a series of shafts or 'wells'; 8 were found by James Beck in April 1938 when the foreshore was stripped of sand in a gale, SE of the site excavated by Worsfold, and more were examined by Antoinette Powell-Cotton between 1954 and 1966. 30 shafts are known, of which 6 were recent; the rest are Iron Age, 'Belgic', Roman, and medieval. These were all nearly destroyed by rapid erosion of the cliff face at Minnis Bay; a photograph in the museum shows the intricate convolutions of the chalk at this point, with deep vertical shafts visible. Most were excavated in difficult conditions when what remained of the shafts were below High Water mark. There seems no doubt that they were inland during their period of use (Champion 1976, 37).

The contents of the first 8 shafts are listed by Powell-Cotton and Pinfold (1939, 191-2): 4 contained datable artefacts, apparently all Roman. This includes the 'Belgic' vase found in shaft 8 (pl.III no.1) which is of Roman grey ware and late 1st century AD. Springs were noted in 3 of the shafts. The artefacts are now in the Powell-Cotton Museum.

Shaft 1 samian, Roman wares.

2 Roman.

3 Roman, including a large grog-tempered jar of post-conquest form -

[1422] April 1938. Grey very coarse grog, pale grey surfaces, smoothed outside.

4 contained some flint-gritted Iron Age sherds, although not mentioned in the report.

5 wooden ?lining.

6,7 chalk only.

8 half a quern, and some early Roman wares (note, above).

Contents noted from shafts found 1954-1966:

9 flint-gritted sherds.

10 flint-gritted and grog-tempered sherds, including thick coarse combed storage-jar sherds; a soft, sandy salmon pink amphora sherd; and a small fine ware base that may be a burnt sherd from a white ware butt-beaker, as well as:

[1372] A3. 248/1955. Thin, brittle, in many pieces, only half left. Brown-red, some grog and white grits, not true grog. Dark brown-grey surfaces, lines tooled outside.

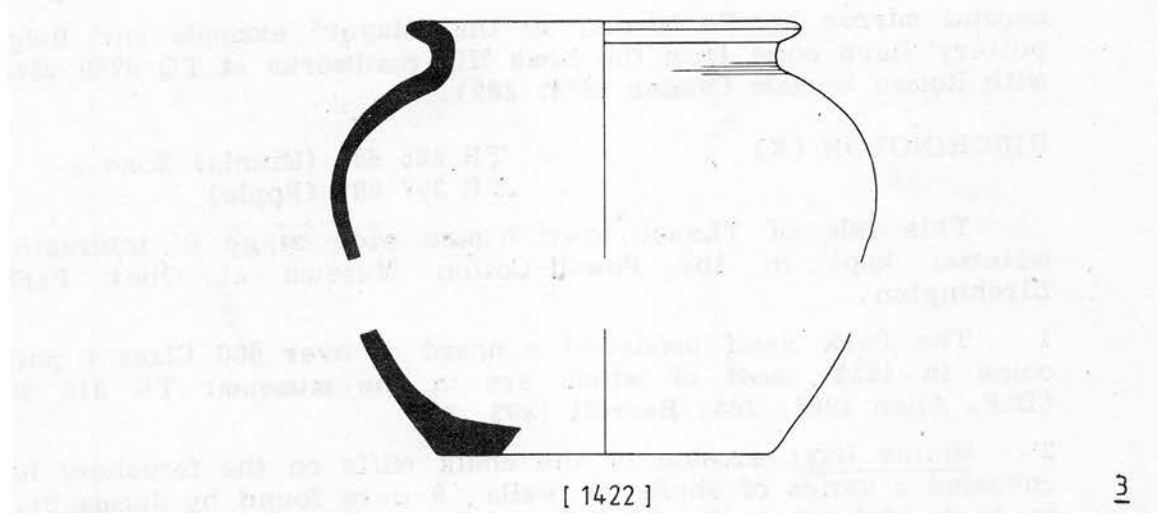

3

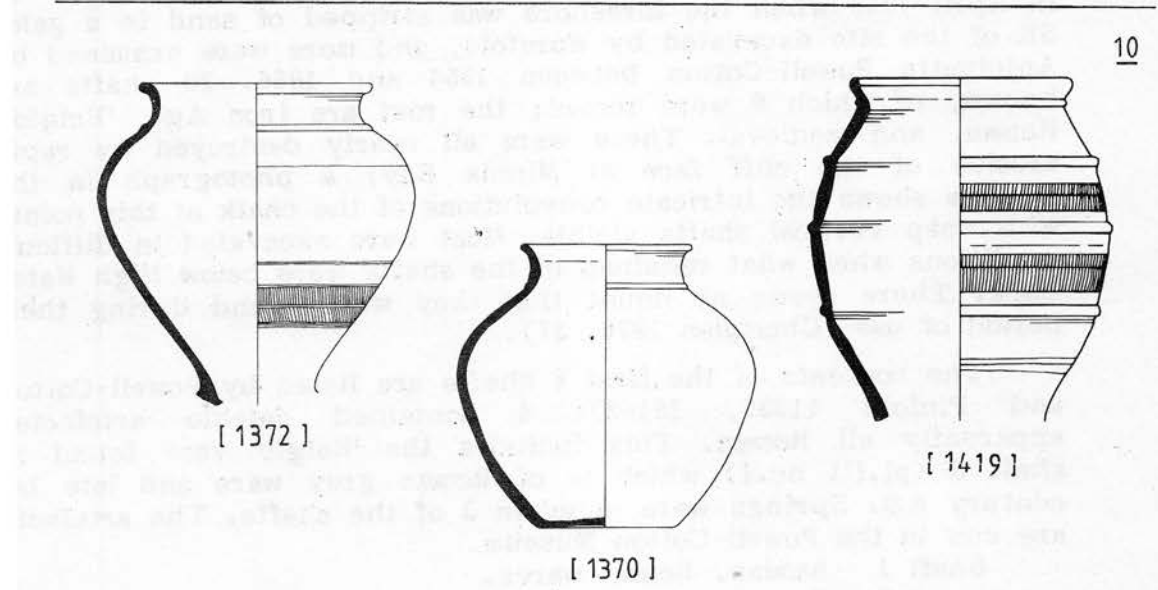

10

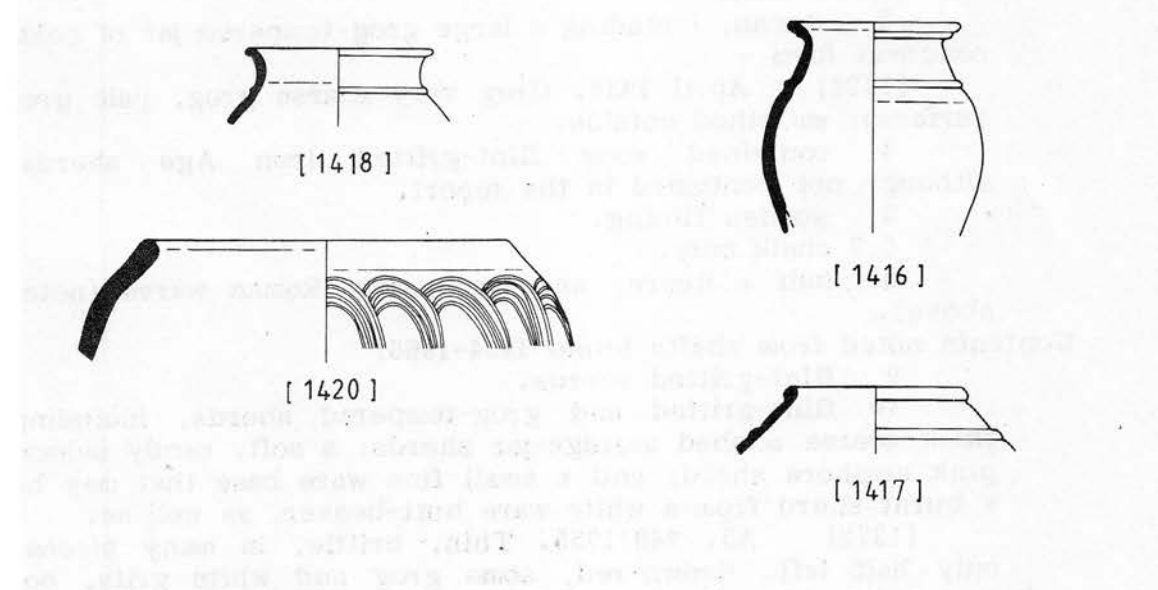
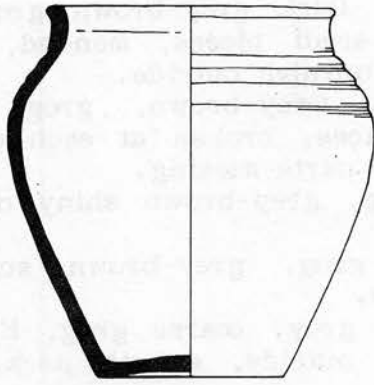
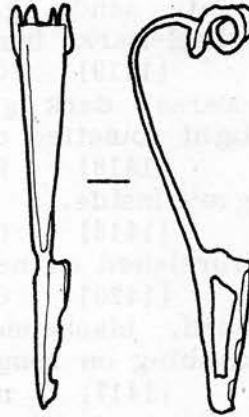

Fig.11: Pottery from Birchington, Minnis Bay. 1:4



[1378]



[1431]

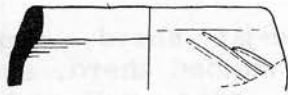

[1421]

11

25

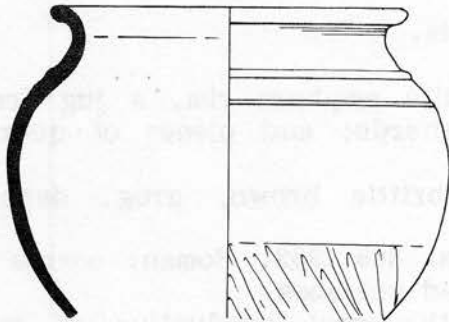

[1440]

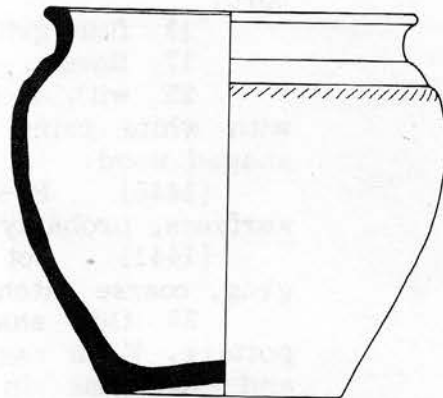

[1441]

Fig.12: Pottery from Birchington, Minnis Bay. 1:4

[1370] B1-2. 250/1955. Dark grey-brown grog with white sandy grits, in many small pieces, mended, worn; wheel-marks inside, remains of burnish outside.

[1419] G5-2. 249/1955. Grey-brown, grog, fairly coarse, dark grey-brown surfaces, broken at each cordon, light rouletted decoration; large parts missing.

[1418] E3-1. Red, grog, grey-brown shiny outside, grey inside.

[1416] G5-4. Brown, grog, grey-brown surfaces, burnished on neck and over rim.

[1420] C3. Thick dark grey, coarse grog, HM, not hard, blackened inside, grey outside, smooth neck, good combing on rough surface below.

[1417] not in series. Buff-grey-brown, finely flint-gritted, but wheel-made; small piece only, grey surface, smoothed.

11 a large combed storage-jar sherd, grog; flint-gritted sherds; one shell-tempered combed sherd, and:

[1378] B2-3. 223/1956. HM, grog, well restored from many pieces, dark grey surfaces, burnished; vertical tooling below shallow cordons. Large pale grey firing patch with cracked surface outside.

[1421] C3. Grey, grog, dark grey surfaces, not very hard.

[1431] 228/1955. Bronze, 2-coil spring with internal cord.

13 flint-gritted sherds.

17 Roman.

25 with a sandy white amphora rim, a jug fragment with white paint; Roman sherds; and pieces of quern and shaped wood:

[1440] B3-4. Soft brittle brown, grog, dark grey surfaces, probably Roman.

[1441] not in series. 269/1963. Roman: coarse grey, grog, coarse patchy grey-red surfaces.

30 this shaft was the most productive of relevant pottery. When examined it was 110 cms deep, 100 cms long, and 108 cms in diameter (Powell-Cotton, Gibbons, and Gibbons, n.d.) and the sequence of discovery, from top to bottom, was vessels 1, 2, 5; brooch; 4, 6, 3, 8, 9, 7.

[1312] B3-7. Pot 1, 273/1966. Grey-brown grog, patchy surfaces, very worn at base and mended from many small pieces; top half well made, mended in antiquity by drilled holes in several places round top. Not more than half extant.

[1320] G5-2. Pot 2, 287/1966. 'From W of shelf', apparently a ledge in the shaft. Dark grey not very hard grog, leans, restored, dark grey surfaces, burnish outside on neck and tooled decoration.

Brooch: 286/1966, gilded bronze, complete, Langton Down form.

[1316] B2-4. Pot 4, 275/1966. Mended but nearly complete. Matt grey, no grog or visible temper, hard grey smooth surfaces, burnish outside, some black deposit.

Pot 6 has not been isolated.

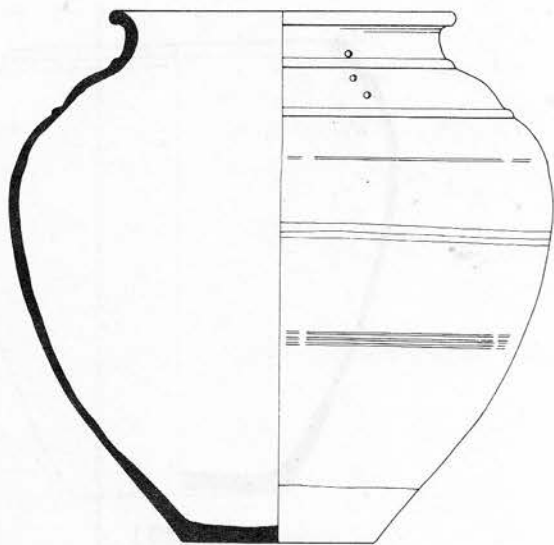

[1312]

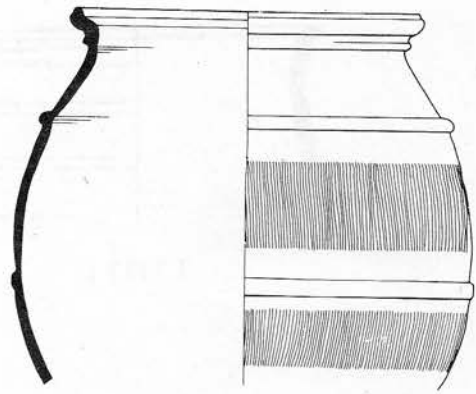

[1320]

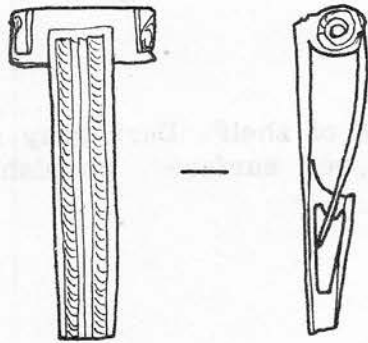

[1318]

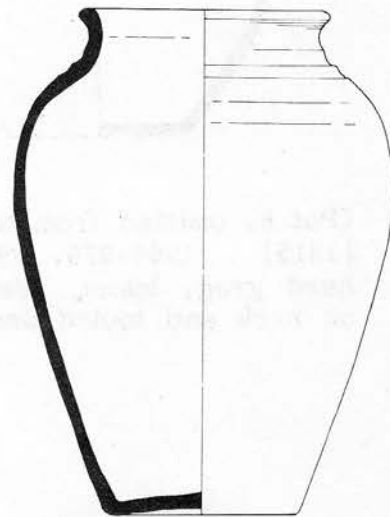

[1319]

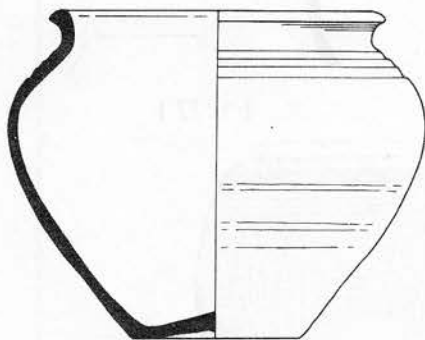

[1316]

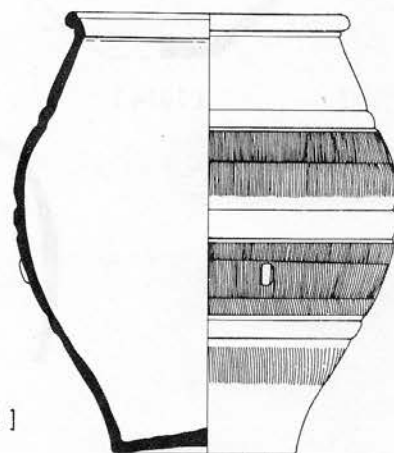

[1321]

Fig.13: Pottery and brooch from Birchington, Minnis Bay, shaft 30. (Pottery 1:4, brooch 1:1.)

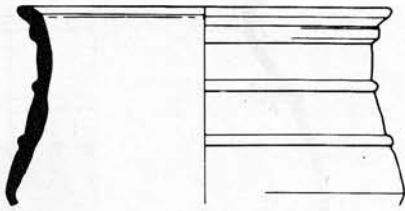

[1317]

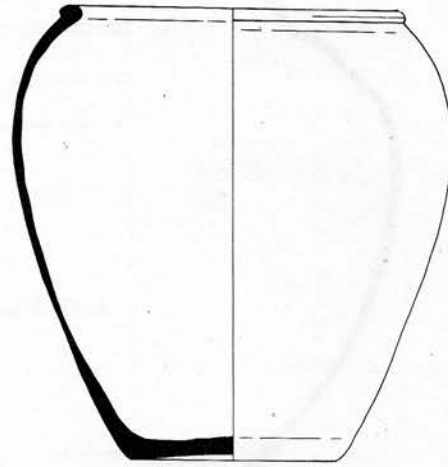

[1313]

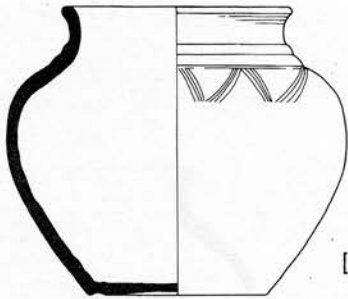

[1315]

(Pot 5, omitted from text):

[1315] 1966.276. '29/5/66. From W of shelf'. Dark grey not very hard grog, leans, restor ed, dark grey surfaces, burnish outside on neck and tooled decoration.

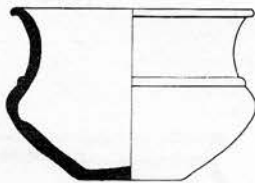

[1314]

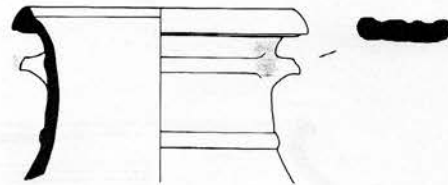

[1322]

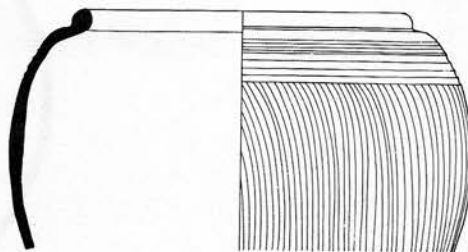

[1373]

Fig.14: Pottery from Birchington, Minnis Bay shaft 30. 1:4

[1319] B2-3. Pot 3, 274/1966. Very dark grey, grog, good burnish on neck, vertical tooling, rather sooty crust from burial.

[1321] G5-5. Pot 8, 278/1966. Dark grey-brown, grog, buff surfaces, grey patches, rouletted and burnished. One lug extant, and traces of another, 1/4 - 1/3 intervals around pot, edges show; apparently stuck on rouletted surface and came off quickly, or came off before rouletting. Leans badly; worn foot.

[1317] E1-2. Pot 9. 289/1966. Pale grey, grog, dark grey surfaces well burnished outside.

[1313] (C2-1). Pot 7. 277/1966. Patchy grey finely flint-gritted.

Also in the shaft:

[1314] E3-2. Pot 10. 278/1966. Fairly hard grey grog and small sandy buff grits, one flint lump, pale grey inside, dark grey burnished outside. Less than half extant.

[1322] G6. Pot 11. 280/1966. Brown grog, soapy buff surfaces, black patches, burnish outside, soft.

[1373] C1-1. Pot 12. Very hard grey grog, some white grits, pale grey inside, dark grey outside.

A quantity of sherds are also marked 'Well 30', including:

[1371] not in series. Dark grey fine grog, smooth dark grey surfaces.

[1376] not in series. Coarse dark grey grog, not hard. Tooled in groove. Does not seem any bigger than this.

[1369] G5-6. Hard grey Roman, some grog, a lot of small white sandy grits, buff core at rim, pale grey matt hard sandy surfaces.

[1374] B2-1. Coarse brown grog, dark grey inside, grey-buff outside.

[1375] C3. Very hard grey grog, some white lumps, grey surfaces, smooth over rim, deep scoring below.

[1324] G1-1. Dark grey grog, burnished inside only.

[1323] L2. Patchy grey-buff, flint-gritted, smoothed outside and over rim.

The fabrics are hard and well made, but not all grog-tempered; some, including coarse combed sherds, are flint-gritted, and some plain body sherds and everted rims have grits and grog. Sherds from combed jars like pot 12, above, are very similar in fabric and degree of hardness to others from Faversham and Canterbury.

The shaft discussed by Ross (1968, 260) is Roman.

3 The Worsfold Collection in MM derives from Worsfold's investigation of the foreshore, 1938-40 (Worsfold 1943). The confused published account of the early Iron Age remains has been re-examined by Champion (1976, 33). The pottery, apparently from an area to the NW of the first find by Beck, includes, as well as large pieces of flint-gritted ware in angular forms, plain rounder forms of the later Iron Age with some flint gritting, and a few Roman sherds; and also a rim sherd from a plain greensand tempered jar of the common Kent fabric, a sherd from a grog-tempered cordoned jar, and two vessels shown here:

[1151] A3. Grey, grog, worn inside, burnished smooth unshiny outside. Rim is in very similar fabric.

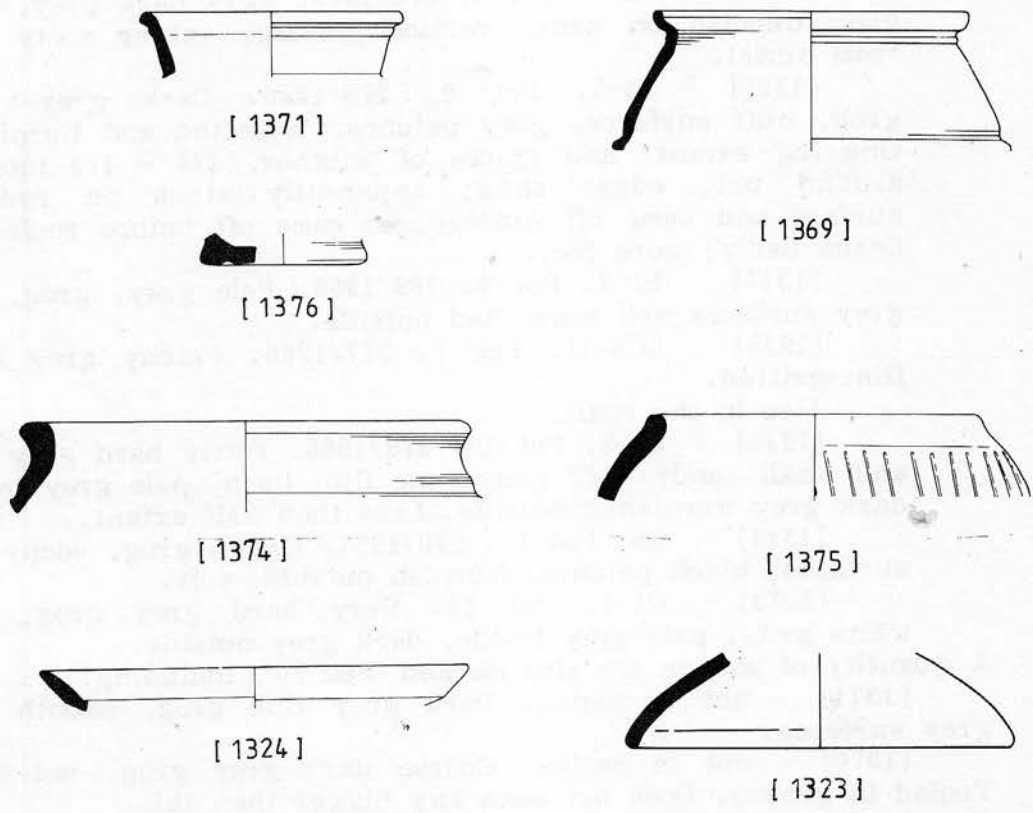

Worsfold Coll.

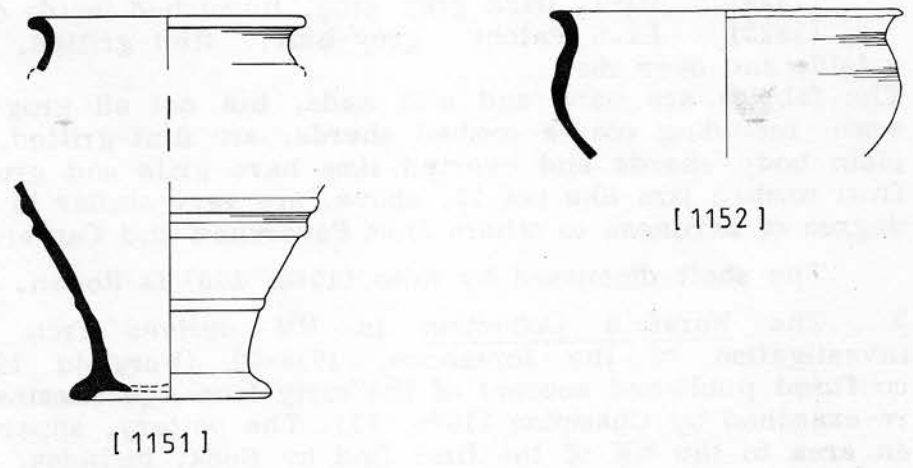

Fig.15. Pottery from Birchington, Minnis Bay. 1:4

[1152] D2-4. Some flint, some grog. Grey with dark grey surfaces, HM.

4 Other pottery and brooches from Minnis Bay in PCM come from observations in advance of contractors' work on the cliff top during construction of the promenade. Various pits were found, with flint-gritted and grog-tempered wares: those from areas including grog are marked 0.6 or 0.9:

[1439] D1-4. 0.6/1960. Grey-brown, HM, grog, some grits, dark grey inside, brown-grey outside, tooled neck, shallow wiped decoration below.

[1414] C7-3. 0.6c/1960. HM, well made, pale grey with large lumps of red and pale grog, darker grey surfaces, burnished a smooth dark grey outside with deep grooves.

[1437] B2-1. 0.6/1960. Grey HM grog, dark grey outside, burnished, bright orange inside.

[1435] B2-1. 0.6/1960. HM dark grey thick grog and flint grit, well finished but not very even; dark grey burnish outside and over rim. Another piece, browner patches, 0.6.1.

[1438] D1-4. 0.6/1960. HM grey grog, smooth; another piece, apparently same pot, darker grey, thicker and less regular. From the same area came a lot of HM flint-gritted sherds, and a probable Roman storage-jar rim with some iron nails. Most of the pottery is in small pieces.

[1436] E1-2. 0.9.2 Grey-brown, grog, dark grey surfaces, burnished well outside and over rim; precise cordons.

[1433] 09.3. 261/1961. Bronze, with iron rod through spring, Colchester type, with stud on end of hook and rouletting on other side of the foot. 'Between Hereward and Sea View Road, Minnis Bay (Collingwood group F), 2 ft down in 0.9/3 large pit cont. mixed RB ?Belgic and gritty sherds from top to base apparently.' (Museum records).

[1520] 262/1961, 'same place, in 09/4 small pit with ash and in the filling cont. Belgic (or RB) sherds and one piece of quern... Collingwood grp.K or KI.' Bronze.

[1432] 263/1962, 'same site, 2 ft 3 ins down in RB (or Belgic) layer above 0.10 ditch cont. skeleton.' The skeleton is earlier Iron Age. Bronze.

[1434] 264/1962, 'in RB or Belgic layer above 05/8 containing gritty EIA sherds. A 2nd pin nearby in poor condition also plain. The RB or Belgic layer was continuous over 0.10 skeleton ditch and the 0.5 pits.' Bronze.

The 'Belgic' pottery referred to is largely Roman, except for a large combed jar of form C4, 267/1963, which is grog-tempered, from between pit 0 and 02, on Grenham Cliff, 'crushed by machine'. There are some TN platter sherds and some St-Remy and samian sherds.

5 South End brickfield, February 1913: to the S of Birchington, c.TR 303 687.

[1415] not in series. 179/1913. Brittle coarse grey, grog, matt grey surfaces, buff earthy discolouration.

6 Epple Bay is the site of various finds of Roman pottery, notably a cemetery found in 1904 in Epple Bay Avenue, between the railway and the sea (Powell-Cotton 1924, 158; VCH 1932,

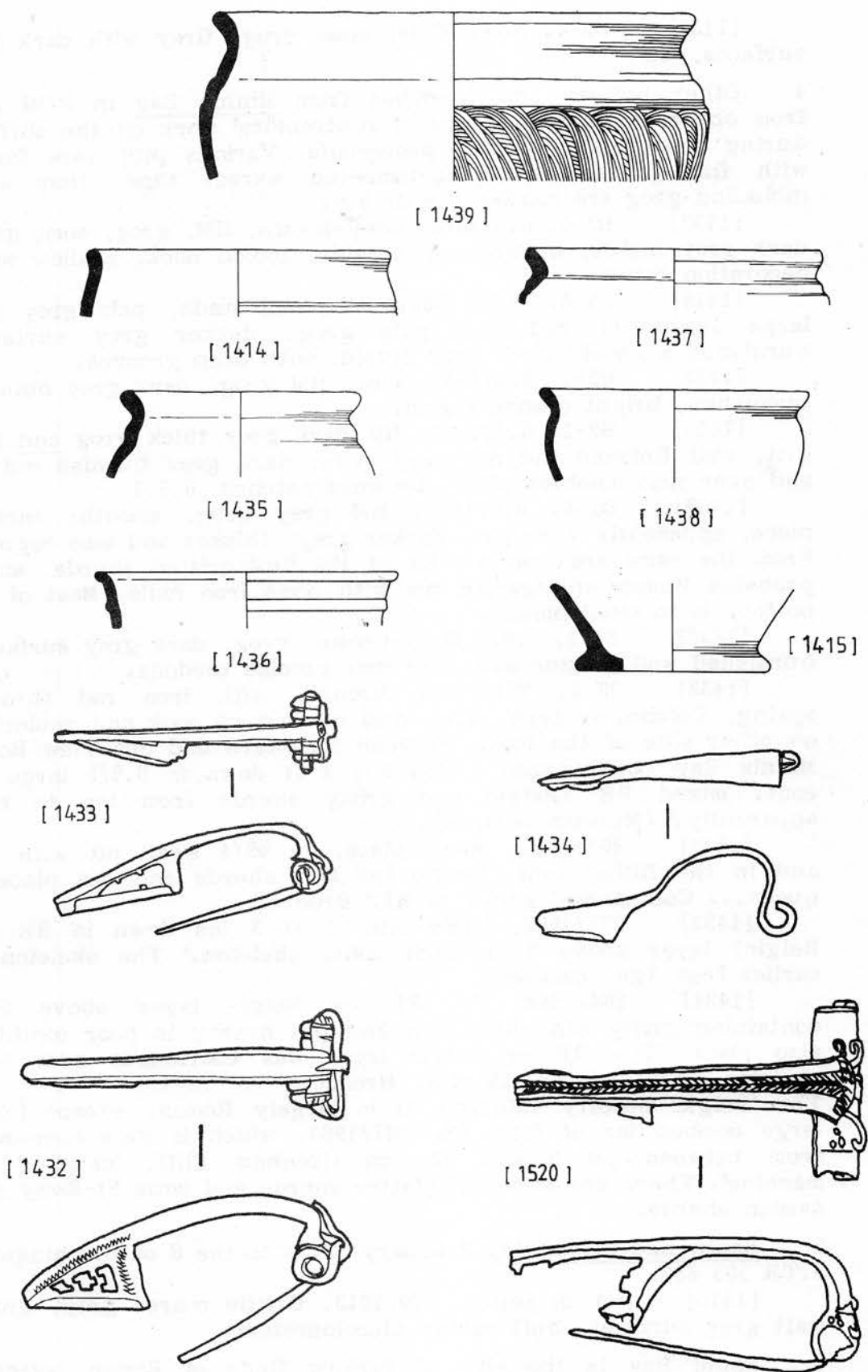

Fig.16: Pottery and brooches from Birchington cliff top. (Pottery 1:4, brooches 1:1.)

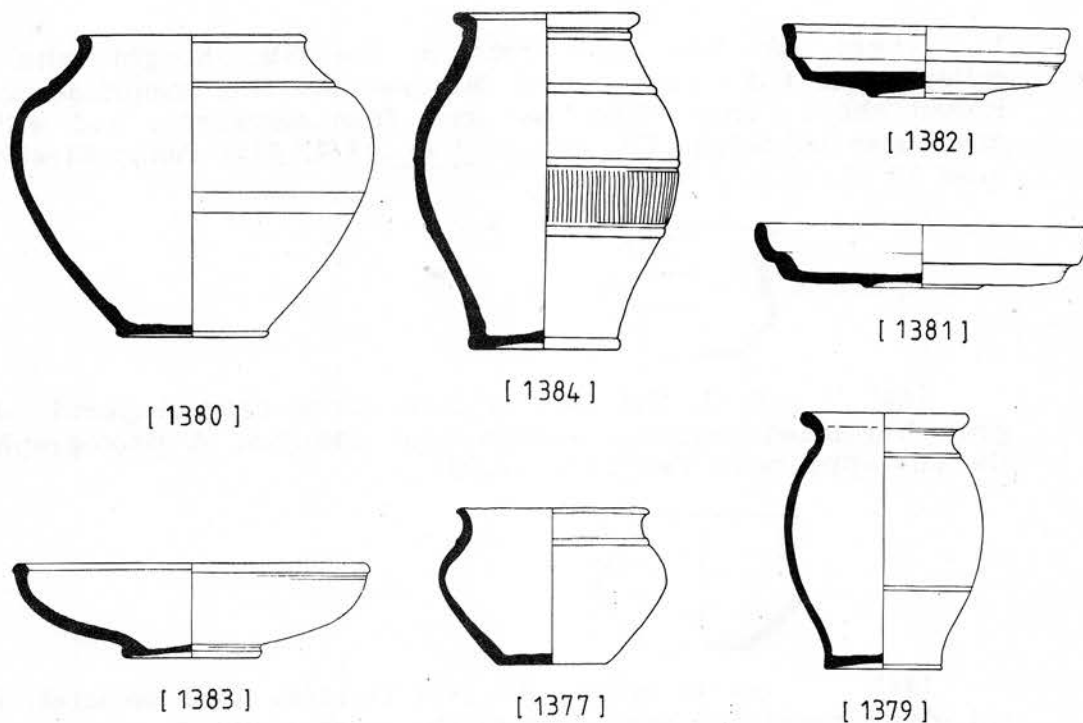

Fig. 17:
Pottery from Birchington, Epple Bay. 1:4

146). The vessels in the PCM include some that are grog-tempered, of the second half of the 1st century AD:

[1380] B1-3. 3/1904. Cracked but almost complete, very well restored, grey-brown grog, smooth surfaces. Groove, not a cordon; a good pot.

[1384] G5-5. 6/1904. Complete, grey-brown grog, thick, patchy buff-grey-brown surfaces. Faint tooled vertical lines on one panel; was tooled shiny on neck.

[1382] G1-6. 14/1904. Dark grey grog shows in rim chip; complete, buff below grey-buff patchy surface, traces of black paint around rim. No shine on surfaces now.

[1381] G1-6. 15/1904. Complete but mended and a bit warped; patchy grey-brown grog, not shiny.

[1383] not in series. Not as elegant as in the drawing; foot shallow on one side, so pot leans over. Grey Roman fabric, pitted and sandy inside, accretions now on surfaces.

[1377] E3-1. 17/1904. Complete, grey-buff, patchy, probably grog - not gritty. Probably HM; some glue or paint now on inside surface.

[1379] E3-5. 12/1904. Complete, grey-brown grog, not gritty, smooth surfaces.

Two large Colchester brooches from Epple Bay are on display. The museum has sherds of Roman date found at Epple Bay in 1911 and 1927.

BLETCHLEY (Bu)

SP 885 334 (Saffron Gardens) Zone 7/8

Published information from Bletchley is so far unstratified.

1 There are two small pots in the BM, bought with the collection of G.F. Lawrence of Wandsworth: this comprises mostly Roman sherds from Bletchley, some from elsewhere, and without circumstantial detail. Cf. Waugh et al. 1974, 412: Fenny Stratford, c.SP 88 34.

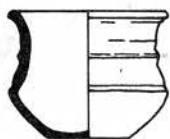

[43] E1-3. BM 1927/11-14/4. Grey grog-tempered, dark grey burnished surface, pinkish near the rim. A photograph of the cup appears in V&A 1952, pl.30.



[44] not in series. BM 1927/11-14/5. '1885' on label. HM, not grog, burnished dark grey-black; much restored.

2 Large quantities of late 'Belgic' pottery from Saffron Gardens, in BCM, were rescued in 1964 from a site on the bank of the Ouzel (Waugh et al. 1974). The site revealed ditches and pits and traces of a riverbank revetment. With few exceptions the fabric is soapy grey, grog-tempered, with red surfaces, including unusual numbers of girth beakers, often decorated with shallow tooled patterns. The chief exception to the use of grog appears in the lid-seated jars, nos.56-67, which are shelly. The forms and colouring are local characteristics; the assemblage is partly post-conquest. There are a few black HM sherds of an earlier tradition, and one or two white butt-beaker sherds.

Those in the type series are:

(Nos.1-9 Iron Age, 10 sandy)

11: G5-4	78: G1-1
16-23: G4	79, 80: G1-6
24, 26, 28, 29: E1-2	81: G1-7
32: E1-4	82: G1-1
33: E1-2	86, 87: A6
34: E3-2	97: G5-2
35: E3-1	98: E3-6, grog and grit
37: B1-5	99: B3-2
38: E3-1	101, 102: D3-4
39: B1-2	104: G4
41-43: B1-1	105: (soft sandy yellow jug rim)
44: B1-5	107: C5-2
45, 46: D1-3	109: D3-4
47: B1-5	110: L5
48-52, 55: C6-1	111: G2-3, grit and grog
70, 73-77: C6-1	112: G2-2

No.50 should be noted, as it was undoubtedly made by the same potter who made an exactly similar storage jar found in the Caldecotte kiln (q.v.), only a few miles away.

3 Shenley Road, site 1, at SP 852 343: 3 boxes of material in BCM were excavated in 1967 by R.W. Griffiths from a 'Belgic' ditch on a Roman site (Waugh et al. 1974, 414). The pottery, not yet published, is very similar to that from Saffron Gardens.