

Gazetteer - Hacheston (S) to Hothfield Common (K)

HACHESTON (S)

TM 313 567

Recent excavations on a rural settlement (Millett 1975, 137; Britannia 5 (1974), 439) have produced some 'stray' early samian (Dannell 1977). The coarse pottery is entirely post-conquest, but includes some late 'Belgic' forms such as storage jars and late versions of small carinated cups, for which grog is occasionally used: in particular for an E1-1 cup with the out-splayed rim considerably larger in diameter than the carination. Two vessels of B2-1 form are not grog-tempered; nor are butt-beakers and large narrow-mouthed cordoned jars. What is grog-tempered is a large slightly curved sherd with a stamped and incised design of lines and concentric circles (S3).

HADLEIGH see SOUTH BENFLEET

HAMPERMILL (H)

TQ 097 941 Zone 7

Structural evidence and pottery have been found at an ill-defined Roman site by a probable ancient ford across the river Colne; it is now waterlogged and much damaged. Samian and 1st to 3rd century pottery were found by Derricourt (1970, 1972); the four 'Belgic' rims illustrated (Derricourt 1972, fig.4 nos.17-20) are not distinctively 'Belgic' in form and no.19 is certainly Roman, from form and description.

Davey (1931) noted many fragments of coarse brownish-black pottery identified by Hawkes as 'late Celtic' at TQ 096 941; those illustrated (Davey 1931, fig.10) are chiefly combed storage jars of the sort that continues in use throughout the 1st century AD, with a few other plain everted rims of indeterminate form. His other finds are Roman, all recovered from gravel quarrying, and unstratified.

Derricourt's main finds are in Watford Museum; some are in VerM.

HARDINGSTONE (N)

SP 764 574 Zone 8

Excavation in advance of a new primary school in St Martins Lane found 4 pottery kilns with traces of others, and a drainage ditch complex (Woods 1969). Ash and structural material from the kilns were found in ditch 1, and a small bronze Colchester brooch came from the upper fill. Only a few vessels came from the kilns, which appeared to be contemporary with the ditches; an iron brooch of pre-Flavian date came from kiln 1, and the pottery matches the upper fill of ditch 1.

Woods dates the kilns to the Claudio-Neronian period, a product of new markets resulting from the Roman advance. The site did not survive the movement north of the army.

Most of the pottery came from ditches. Two points are worth noting:

1 The majority of the coarse wares are shelly; the majority of the fine wares are tempered with limestone, ironstone, haematite, or mixtures. Only occasionally does grog appear, and not at all in the coarser wares. Woods describes the fine wares as 'Romanized' and dates them to the 'mid- to later 1st century A.D.' (Woods 1969, 7).

2 The ditches are stratified. Much of the pottery comes from ditch 1; the 'Belgic' forms were found in the upper fill. None occurred in the primary or middle fills of this ditch, which were full of coarser wares. The primary fill pots are plain HM Iron Age types; those of the middle fill are ledge-rimmed shelly jars that were being made locally and are 'the most characteristic product of the Hardingstone kilns' (*op.cit.*, 8). Woods dates the kiln products to the mid- to later 1st century, contemporary with the 'Belgic' forms in the upper fill of ditch 1; rather less well made versions, however, comprise the middle fill of the same ditch, and it is these which most strongly resemble the ledge-rimmed coarse jars of Herts., with rilling on the body and slashing on the rims.

Northamptonshire County Archaeological Unit has most of the finds; but many of the 'Belgic' types are with the excavator.

The material from D. Jackson's excavations of kilns and ditches to the NW of the Primary School site is in NM, and is not 'Belgic' but later.

As very little of Woods' pottery is grog-tempered, only the vessels of fig.12 are in the type series. I have seen several of the other vessels of possible 'Belgic' forms, in figs.13-15, and none of them are grog-tempered; several are Roman.

The exception is no.37, in fig.10, which is form C7-2 and pale red-brown buff with grog and quartz.

Fig.12:

- 69 E1-1. Brown-red, thin and hard with magnetite and ironstone; a very few small pieces of pale grog.
- 70 E2-1. St Martin's Lane, unstratified. Brown core, pale red surfaces, much grog.
- 71-3 E1-1. Not seen.
- 74 D2-1. Grey, much grit of various kinds.
- 75 not in series. Not seen.
- 76 E2-1. Hard dark grey, chalk and haematite.
- 77 D1-2. St Martin's Lane, unstratified. Brittle pale buff, grey core, haematite.
- 78 D1-2. Not seen.
- 79 D1-1. Not seen.
- 80 D1-2. Grey, gritty.
- 81 S1. Not seen.

HARLOW (E)

TL 4680 1230 (temple) Zone 7

The 1st century pottery and brooches from the site of the Romano-Celtic temple found by Wheeler (1928), and in a sand-pit W of the Roman road, found by Miller Christy (Wright 1925-27; CMR 1927, 19) are all post-conquest, including early Roman versions of rilled jars, now in CM. Excavations by the West Essex Archaeological Group during the expansion of Harlow New Town, however, did find late pre-Roman material of considerable interest on the temple site, in a soil layer on the hill top beneath the accumulated Roman debris (Davison 1973; Selkirk 1968). A few post-holes were the only structural evidence; the site may have been an open-air shrine. Much pottery and great numbers of brooches and coins were found (see D.F. Allen 1967). The pottery is in PEM; it shows an appropriate range of fine wares suited to late 'Belgic' pottery, with many copies of Gallo-Belgic forms.

A little earlier Iron Age pottery was found at the temple site; otherwise Iron Age and 'Belgic' occupation was unknown in the area except for a scatter of sherds at Great Parndon (Bateman 1969, 20; pl.4). Now another body of material has been salvaged at Holbrooks warehouse on Templefields industrial estate, close to the temple site (Conlon 1973; TL 470 127). The two pits that were the only Iron Age features recorded produced large storage jar sherds and other 1st century AD wares; other finds included many 1st century brooches and 32 bronze British coins, 6 uninscribed. None of this is yet fully published (see Britannia 11 (1980), 378).

HARPENDEN (H)

TL 144 150 Zone 7

1 A 'chieftain burial' was found in 1867 when the railway was built; one cinerary urn and a collection of shale and bronze objects made up the group (Bagshawe 1928; Freeman and Watson 1949). There is no surviving pottery. Luton Museum.

2 Some unpublished settlement evidence is known from c.TL 14 14, Crabtree Lane, found in 1938 in a small gully (Holmes 1958-61, 96).

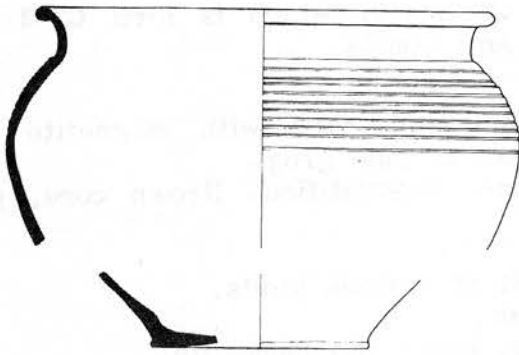

[757] C7-1. Grey grog, quite coarse at base but well made, finely shaped and rilled.

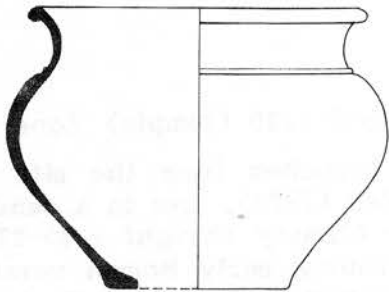

[758] D1-1. Post-43, high-fired fine pale grog, buff inner surface showing grog but very smooth, patchy dark grey outside, worn, smooth but not burnished. With these two early post-conquest pots were a triangular loomweight and a piece of ornamental bronze, found under layers of Roman wares including Claudian and later samian: now in VerM.

HARROLD (B)

SP 956 566 Zone 8

The site designated as Harrold 1 (Hall and Nickerson 1966, 1) consists of ditches found in building, and a pit in a sand quarry; the site runs over into Odell parish (q.v.) (Hall and Nickerson 1969).

The Pit: nos.99-109. Contrary to the report, this group is likely to date later than AD 10: it is described as wheel-thrown, well made, and hard. The absence of imported forms or copies is no argument for a necessarily early date (see notes on Zone 8). Those in the type series are:

- 99 E3-4. 'Light brown.'
- 100 F4. 'Orange... shelly.' A rare type, otherwise smaller.
- 101 E1-1. 'Orange,' and a common local form.
- 102 E3-2. Shell.
- 103 B2-3. Shell.
- 105 B2-3. Sandy.
- 106 B5-2. Orange, shelly.

The other group of vessels is from the ditches, and unstratified; no.118 is a post-conquest form, and the platters are late. In general these forms appear later than the pit-group.



- 112 D3-4. 'Pink.'
- 113 E1-1. 'Darkened orange... a few fine shells.'
- 114 (G1-9). Shelly, black.
- 115 G5-5. Orange.
- 118 G2-3.

These vessels are in the mixture of fabrics common in the region, with much shell used, and frequently orange in colour. Hall and Nickerson (1966, 2) point out that 'Belgic' pottery is found on sites in the area which are also Roman, and seldom on sites with earlier Iron Age wares. Excavations in conjunction with gravel digging at SP 953 573, N of the village, found ditches with Iron Age pottery, and Anglo-Saxon burials, but no 'Belgic' or Roman pottery (Eagles and Evison 1970).

HARTWELL (Bu) SP 802 124    Zone 7

Two vessels from 'the Brickfield', found in 1909 (Waugh *et al.* 1974, fig.14, nos.56-57):

- 56 B1-1. Soft soapy grey-brown, grog-tempered.
- 57 C7-1.

A few other pieces are in BCM store: two B1-1 rims, grog-tempered; a rim like no.57, apparently without grog; a plain gritty base; and a rim sherd from a handled bucket like Gun Hill no.80, in a sandy dark grey ware. BCM 2.09.

HASKETON *see* BURGH-BY-WOODBRIDGE

HASLINGFIELD (C) c.TL 40 52    Zone 9

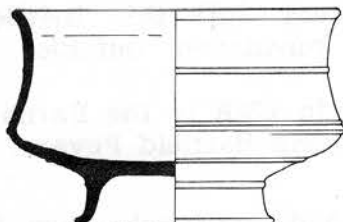

[880] F3-2. CambM 1912.287 (1912.73.AR). Mended, complete, apparently grog; not gritty. Hard, buff inside, flaky dark grey outside, much burnished. Well made. This fine vessel (Fox 1923 pl.XII, 1) was apparently found with a weaving-comb and a disc-headed pin (Fox *op.cit.*, 91). It now contains 4 small fossils, Cretaceous Echinoids to judge by BM 1975, pl.68. There are no other circumstantial details.

HATFIELD PEVEREL (E) c.TL 793 098    Zone 1

Iron Age, 'Belgic' and Roman pottery has been found in the area of a brickfield at Nounsley, on the riverbank S of the village.

1 c.1900 a large pedestal urn was found but not preserved; in 1928 'two cinerary urns were found close together' (CMR 1929, 10): pl.II:

- 1 A1. CM 419.1928. Dark grey, not burnished, red where flaked, grog at core. Contains bones, two burnt stones,

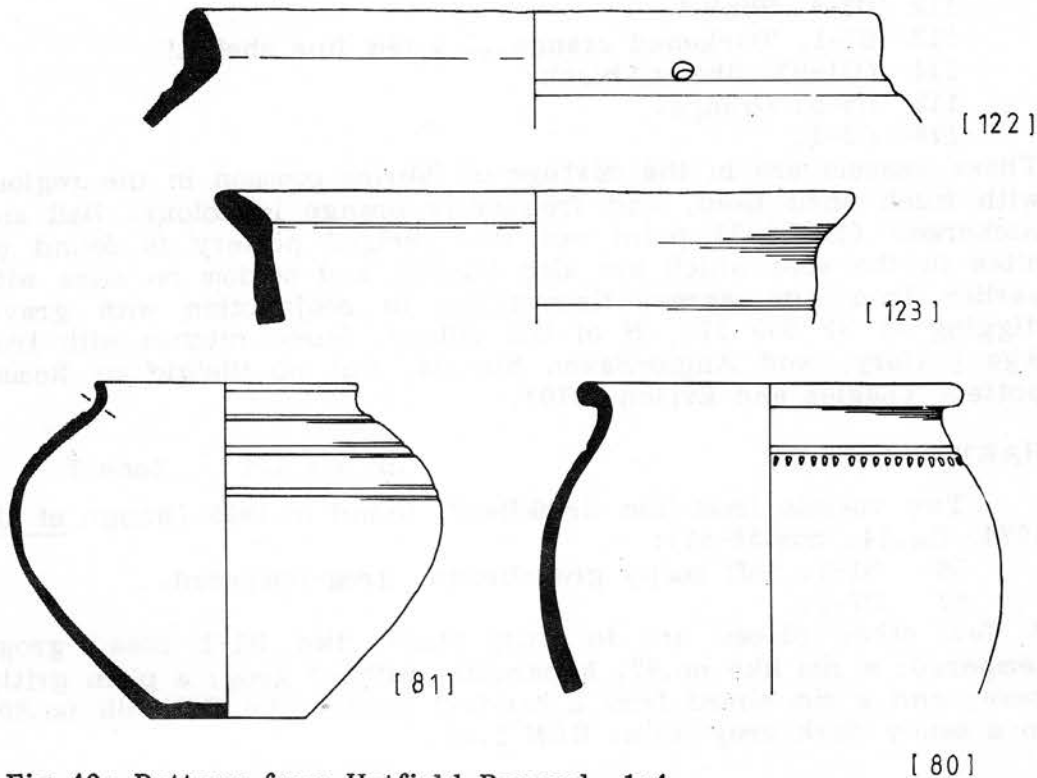

Fig.42: Pottery from Hatfield Peverel. 1:4.

and the iron fibula fragment noted in CMR (too small and corroded to discern the form).

2 [81] B3-4. CM 420.1928. Very soft thin brittle brown grog, smooth buff inside, brown burnished outside, slightly soapy. Now in many pieces.

This is the actual vessel; that shown in CMR is the Barnston pot, used as it is of similar form. This second Hatfield Peverel pot also contained bones when found.

2 'Numerous fragments of pottery' had previously been found in the quarry, and a short distance to the S, in the same brickfield, two 'hearths' were found in March 1928: hard fired-clay oval patches with coarse gritty sherds. CMR 1929 pl.II nos.3 and 4 were found in one of these: no.3 is a large storage jar rim fragment; no.4 is of indeterminate form.

3 'About a dozen graves' were found in the quarry in February 1931, 300 yds SW of (1). Eight are described and illustrated in CMR 1931, 29: they are all of late 1st century Roman date, if not partly later. The platter shown by Welsford and Rudsdale as 'Belgic' is one of these (CMR pl.VII no.6): it is Roman, with a red core, small white grits, and flaking grey surfaces (CM 1246.1931): pl.VII:

- 1 C6-3. Grave 2; with bones only.
- 7 L6. With a Cam.120 of Flavian date.

4 CM store also contains a quantity of Iron Age and very gritty Roman sherds, evidently found at Nounsley: the Iron Age and some Roman pieces 'found during winter of 1929 and before', with some iron slag, a loomweight, and flints; the gritty Roman wares

found in 1931. Two interesting 'Belgic' rims as well as some small sherds are with the Iron Age material:

[122] C6-1. Grey-brown HM grog, patchy brown-red surfaces, smoothed and tooled outside and over rim. One suspension hole survives.

[123] D1-4. Hard HM grey grog, dark grey surfaces, brownish on rim, tooled outside and over rim.

These are typologically early specimens. Also present, in the type series, is one Roman piece.

[80] C6-3. ?1930. Roman, very sandy, some grog, very worn grey-brown surfaces with red below, pale grey core.

#### HAUXTON (C)

TL 432 528 Zone 9

Many discoveries were made in the area of Hauxton Mill during coprolite digging in the late 19th century (Fox 1923, 111). As well as pottery covering much of the Iron Age, and a Roman cemetery (Liversidge 1977, 28-29: TL 434 526) there is an interesting 1st century AD burial and some additional 'Belgic' pottery that points to a late Iron Age cemetery.

1 'Hauxton, Cambs., March 1889 (with bronze fibula), Baron A. von Hügel, M.A., 1895': CambM 1895.131-2.

[921] (G5-1). 1895.131. Restored but substantially complete: local sandy ware, inside now plaster, outside patchy grey-buff. Must be one of the very largest butt-beakers.

[922] (G5-5). 1895.132. Pale orange-buff sandy ware, smooth and tooled orange surfaces, fine rouletting.

These two pots were found with a loose-plate thistle brooch (Fox 1923, pl.XIII, 1). This is now with 1907.476, below.

Other finds include:

2 [923] B3-8. CambM 1883.187. '?Hauxton, Cambridgeshire, 1841. Camb. Ant. Society 1883.' Restored, especially the rim: local sandy fabric, dark grey-orange patchy surfaces, fairly smooth.

1883.188, also '?Hauxton', 1841, Camb. Ant. Society, is a barrel-shaped butt-beaker, 16 cms high, in local sandy orange-red, neatly rouletted.

3 Z.22202, 'Hauxton Mill N of river, June 1886', and 'Hauxton, April 1888'; all earlier Iron Age, and a hard dark grey barrel-shaped butt-beaker, upper half, no grog: 'Hauxton, TMcKH' (McKenny Hughes).

4 Z.23190, 'Hauxton 1889', two bronze plates, square and embossed, and a piece of decorated bronze folded over.

5 Z.22001, a shelly flat base, 'Hauxton': 'Phosphate Diggings NE of Hauxton Mill': see Hughes 1891, who mentions many finds of all kinds and dates.

6 [914] B3-6. CambM 1907.37. 'Hauxton Mill 1907', from Leonard Wills. Hard gritty blue-grey grog, buff-grey matt surfaces. 'E of road N side.' With a few butt-beaker sherds, and some early Iron Age angular sherds.

7 [924] B3-8. 1907.476. 'Hauxton, C. The Baron A. von Hügel.' Hard grey early Roman, bandaged inside, much spalled

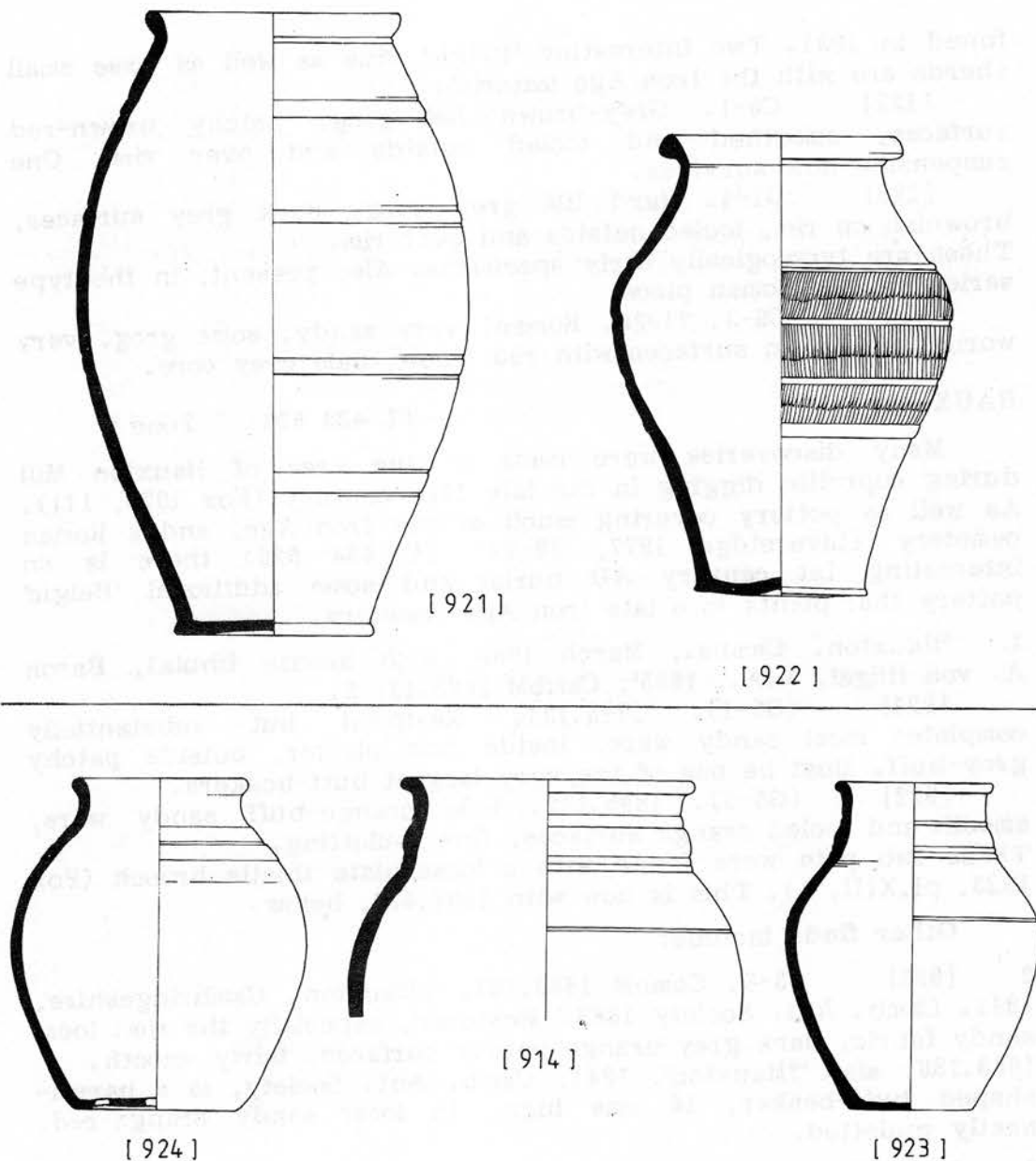

**Fig.43: Pottery from Hauxton. 1:4.**

outside; dark blue-grey surface. 'Cordons' formed by tooling on either side and in grooves between. 4 random holes drilled in base after firing.

All of these are in CambM.

HAYES (K)

c.TQ 40 66 Zone 3

Three vessels were found here in 1937 'during excavations for a new school', and sent to the BM by a Mr Randall who refused to give any more details.



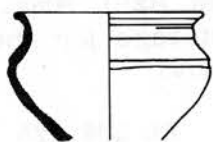

[29] E3-3. Hard sandy brown fabric, burnt black in places, pale grey-brown inside and spalled patchy brown-black outside. Probably Roman.

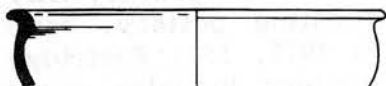

[30] G2-2. Fairly hard dark brown with grog and other grits, patchy brown-black surfaces, burnished rim.

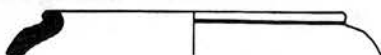

[28] not in series. Soft red fabric with pale grey core at shoulder and rim; rough and cracked.

HAZLEMERE (Bu)

SU 895 954 Zone 7

Sherds from a ditch in Taplin's brickfield, c.1913, include, as well as Roman, a storage jar rim, a rilled and combed sherd from a storage jar, and 3 grog-tempered C1-2 rims (Waugh *et al.* 1974, 413). BCM 297.13.

HERNE BAY (K)

TR 155 675 Zone 5

1 A burial group was found at Studd Hill 'by Lesley Middleton and Lloyd Mingham, 1955', comprising 3 pots and some burnt bones (Jenkins 1962, fig.2 nos.10 and 11):

10 D1-1.

11 E1-4. The published drawings are a little smaller than 1:4.

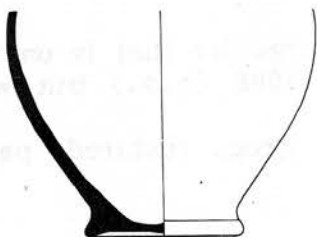

[820] not in series. Herne Bay Mus H.385. Studd Hill 1955/2. Dark grey, gritty, hard, early Roman, apparently. The burial is early post-conquest in date, to judge from the fabric, but native in tradition. Studd Hill is a housing development on the coast W of Herne Bay.

2 Herne Bay Museum also has a quantity of settlement rubbish from Studd Hill, the Marsden Collection of 1955-57. The pottery is very mixed, including Iron Age flint-gritted sherds, grey Roman wares, and medieval; a quern fragment, a Roman Cam.258 (C4), a

jug handle, a Cam.113 base and some B2-1 rims. The only true grog belongs to some coarse combed storage jar sherds, which can be post-conquest. Herne Bay Mus. H.386.

HERTFORD (H)

TL 338 125 Zone 7

1 A large settlement at Foxholes Farm has recently been excavated in advance of gravel extraction; as well as earlier and later material, there was intensive late Iron Age occupation but the site was abandoned thereafter until the 3rd century AD. The ditch lengths have produced much interesting pottery, some in levels without Gallo-Belgic wares (Selkirk 1975, 153; Partridge 1974, 25; Britannia 10 (1979), 305). The pottery includes several unusual and elaborate forms.

2 Queen's Hill, apparently NW of the town centre and a late Victorian development, is the source of a much damaged carinated cup very similar to those at Prae Wood:

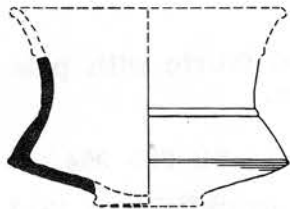

[1058] E1-2. Grey grog, pale red unburnished surfaces. The vessel has been wrongly restored to E1-1 form, to fit the lid, below. The word 'Queen's' is now missing from the paper label inside the pot; there are no records of its discovery.

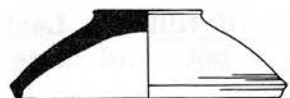

[1059] L7. Gritty pale red, restored, apparently no grog; dark grey patch inside, outside burnished rather roughly. Hertford Museum.

3 Also in Hertford Museum is a large jar that is on the shelves with pottery from Welwyn Grange, 1908 (q.v.) but without any indication of its provenance:

[1056] C1-1. Rough HM jar, grog, restored, patchy grey-buff.



The rich 'chieftain' grave, with satellite burials, is sometimes referred to as Little Amwell, Priors Wood (Holmes 1958-61, 98). It was found in the digging of a drainage trench and much damaged by building work; later excavation recovered the roughly rectangular plan of the burial pit and most of the contents (Holmes and Frened 1955-57, 1). As well as pottery, it contained a Dressel 1 amphora, a glass bowl, an area of calcined bones, and iron, wood, and decorated bronze fragments with 'enamelled' studs. Some, but not all, of the pottery from the main grave was published: fig.4:

1 A2. BM 1958/7-4/723. Grey grog, pale buff-red surfaces, neat base. Was in many pieces, restored.

2 (E3-4). BM 1958/7-4/718. A much mended coarse hard red pot, apparently a Roman fabric, but now hard to tell what is not restoration.

3 E1-4. BM 1958/7-4/721. Grey grog, perhaps once tooled outside, patchy grey surfaces with redder grog showing.

4 E1-3. BM 1958/7-4/719. Substantially complete, mended. Grey grog, buff inside, patchy buff-grey outside.

5 G3-2. BM 1958/7-4/720. Substantially complete, mended. Dark grey grog, buff patch inside, smooth, patchy tooled dark grey outside. This is the pot whose association with the grave is doubtful.

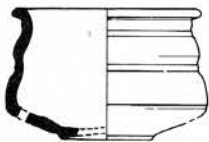

6 [977] E2-1. BM 1958/7-4/717. Reddish grog, very badly restored.

Also from the main grave are these:

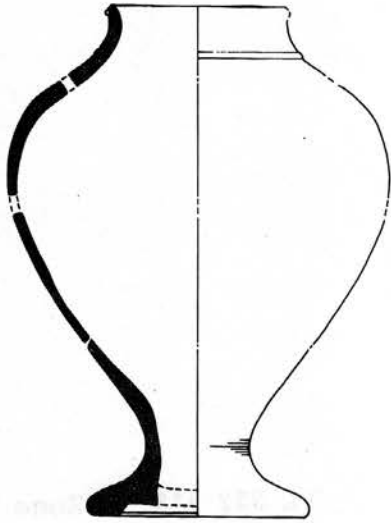

[982] A1. BM 1958/7-4/695-716. Fragments only, grey grog, worn dark grey inside, buff-grey patchy outside, smooth but not burnished.

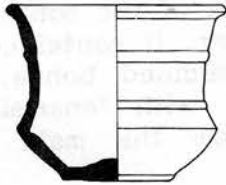

[978] E1-3. BM 1958/7-4/722. Restored, grey, grog, patchy grey-buff surfaces; shows much grog where worn under base.

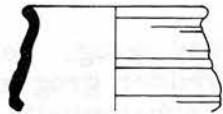

[980] E2-1. BM 1958/7-4/669-694. Grey grog, worn patchy buff surfaces, red at rim. Paler than the other E2-1. Possible base fragments like the other example, but very small and may not belong.

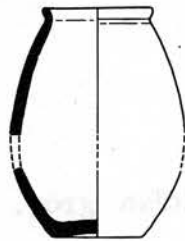

[979] B5-1. BM 1958/7-4/548-602. Grey grog, slightly red at rim, dark grey burnish outside. In many pieces and hard to reconstruct.

The main grave is not as late as the satellites, which were salvaged during building; their pottery, shown in Holmes and

Frend (fig.5 nos.2-5), is later 1st century AD Roman. The large jar, no.4 (BM 1958/7-4/726-795) is in Roman coarse ware, red below dark grey surfaces, and was found with the Cam.227, no.3; the Roman jar no.5, 'slate-grey', was with a 'cooking-pot of Romanized Belgic type... in hard sandy pale brown ware' and a Roman flagon. The Dressel 1 amphora neck, fig.5 no.1, is apparently from another grave in the satellite cemetery, with the small round pot no.2; these were found by a mechanical digger with a brown jar which broke in pieces and was not kept. The amphora body was not present; they all came from a pit, according to the finder. The globular pot, however, is not a 'Belgic' form, and the amphora was clearly old when buried.

All the excavation notes are in the BM, with flint-gritted hand-made sherds and some Roman sherds from 'Iron Age pits east of main burial' and 'ditches'.

The date of the main burial is doubtful, due to the circumstances of its discovery: the amphora and one of the pedestal urns support an early, i.e. 1st century BC, date; the fig.4 no.5 pot is apparently derived from a samian form but is only doubtfully associated, and fig.4 no.2 is a vessel of anomalous form and fabric. I would have considered it Roman, but it is too over-restored to be certain of its allegiances without taking it to pieces. It is true that there are late versions of the A2 pedestal form in Herts., but this vessel does not seem anything but genuinely early. On balance I would consider the grave early, but contaminated.

Stead (1967, 52) gives a complete list of the glass, bronze and iron objects from the main grave. He places it between the Welwyn Garden City and Mount Bures graves in his chronological table, on the grounds that the Hertford Heath pottery is later than that of Welwyn Garden City. Its absolute dating is vague but may belong to the end of the 1st century BC.

#### HEYBRIDGE (E)

TL 850 082 Zone 1

1 Langford Junction, 1888: VCH 1963, 146, gives a list of Cam. types found here when the railway was put in. It includes a considerable range of Gallo-Belgic types and their copies, and forms that are largely post-conquest at Camulodunum. Coins, now lost, included republican and Augustan as well as Claudian types.

2 CM 2470-2474.1912, 'found in the New Cemetery at Heybridge near Maldon from 1909 to 1912'. These are from burials: as well as those drawn here, the remaining sherds show that other vessels were found but broken up and only a few tantalising fragments remain. One or two Roman rim and base fragments are included, with a Cam.218 with criss-cross decoration on the shoulder, like one from Billericay, in a thin red fabric with small white grits (CMR 1913, 1915).

[1100] B2-4. CM 2470.1912 (=AB 140). This is the vessel found with an Arretine platter base used as a cover (AB 139). HM, restored, part of rim missing; grey grog shows in fork marks on surface; patchy buff surfaces, burnished outside. Contains bones.



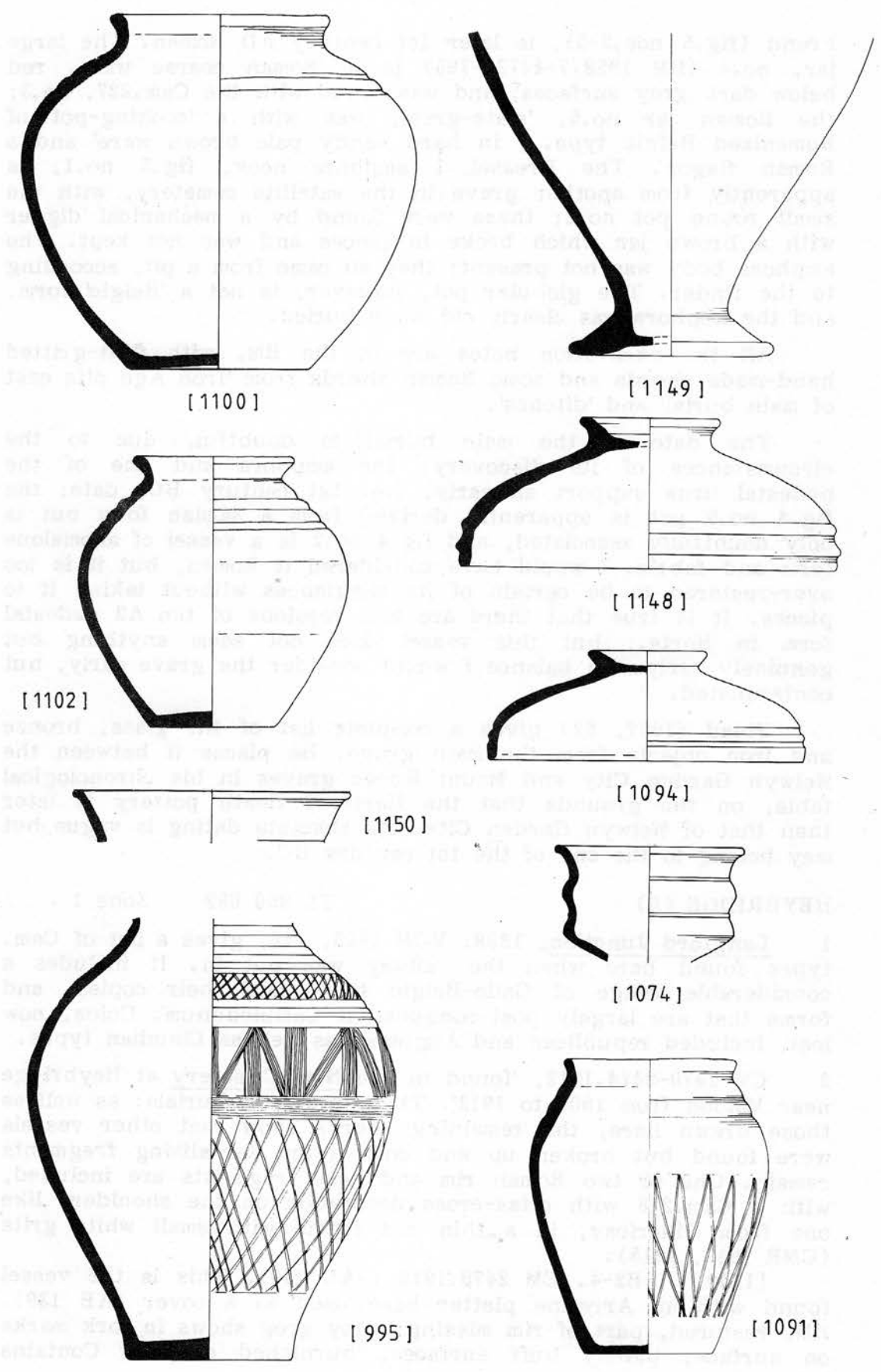

**Fig.44: Pottery from Heybridge. 1:4**

[1149] A1. CM 2473.1912. Hard heavy brown-grey grog, dark grey surfaces, burnished outside.

[1102] B2-4. CM 2471.1912 (=AB 194). Uneven, distorted; complete except chipped rim and 2 holes in side. Lumpy brown-grey grog, patchy grey-brown surfaces, burnish outside except centre strip; very dark rough burnish on lower half.

[1148] L5. CM 2472.1912 (=AB 213). Well restored, finely made lid, grog with pale grey burnished outside and darker grey inside, very neat burnish.

[1094] L5. CM 2473.1912. Dark grey, very hard, grog, possibly romanised; dark grey surfaces once smoothed outside.

[1150] not in series, but probably E1-2. CM 2473.1912. Fine grey grog, smooth dark grey surfaces, very neat, highly burnished.

[1074] E2-1. CM 2473.1912. Hard grey grog, dark grey surfaces, burnished outside.

Two more vessels were found later:

[995] B3-7. CM 3979.1920 (=AB 196). Restored but not distorted. Grey grog, patchy grey-brown surfaces, smooth outside. Burnished decoration, black 'paint' for 2cms around base. Contains bones.

[1091] B2-3. CM 3980.1920 (=AB 195). Complete but for rim chip; HM grey grog, dark grey surfaces, rough burnishing and roughly burnished lines, not well ordered.

Also in CM is the Cam.183B amphora (Peacock 1971, 184). W. Rodwell (1976a, 319) suggests that the Dressel IB rim listed by Peacock (*op.cit.*) as from Maldon, accessioned in 1913, is in fact from nearby Heybridge; this is not unlikely as so far no 'Belgic' material is known from Maldon. Rodwell also refers to a southern Spanish amphora, Cam.185A.

3 Crescent Road (TL 8502 0823): a site on the gravel terrace along the Blackwater was excavated in 1972. An area of 1600 sq m revealed some pits with 'Belgic' pottery. One pit was timber-lined and contained a residual potin coin (Drury 1972; Drury and Wickenden forthcoming). There were some earlier Iron Age features. The site is at the point where the rivers Chelmer and Blackwater join and widen into the Blackwater estuary.

4 Osea Road: a Red Hill excavated by the Colchester Archaeological Group at TL 887 075 produced details of the salt-manufacturing process (de Brisay 1972; 1973; 1975, with distribution map). The pottery, 'Belgic' and Roman, was scrappy and scattered. Discernible forms, of those published, are:

no.1 (de Brisay 1972): C6-1. From the bottom of Tank X.

no.2 G5-1.

no.8 B1-1. This and the above both from the working floors of the 'Southern Group', where most of the 'Belgic' sherds were found.

no.23 (de Brisay 1973): C4, vesiculated; 'found between two clay silt lines on top of a briquetage layer'.

A sherd from some sort of Gallo-Belgic beaker type (no.56), an unstratified rim sherd of a Dressel IB amphora, and some early samian as well as Roman pottery were also found, but none were substantial, and there were no groups.

Radiocarbon dating of a sample of carbonised wood produced a date of 239±63 BC (Switzer 1974, 44). See also W. Rodwell 1979 for discussion of structural and procedural evidence in Essex Red Hills, with a gazetteer.

HIGHGATE

TQ 258 905

The products of the earliest phase at the kiln site in Highgate Wood in north London are grog or grass tempered. The excavators dated Phase 1 to c.AD 50-60, but it is probably a little earlier, perhaps c.AD 40-50. There is no real sign of any post-conquest influence, although the range is fairly limited; the site, however, is some distance from the main area of pre-conquest settlements. The kilns of phases 2-4 flourished during the Roman period supplying the London market. It is doubtful, however, that there was a market to supply in London in the immediately post-conquest period (see below under London).

See Brown and Sheldon (1974) for the pottery of the first phase, and previous references. The roundness of the carinated forms is a typologically late feature; but the fabric of the 'Belgic' forms is native. The bead-rim jars are grass-tempered, and not shelly (unlike Herts.). There is no actual kiln evidence for Phase 1: the pottery came from a 'circular ditch defining the working area' (Brown & Sheldon 1974, 224). The grog-tempered sherds have brown or reddish surfaces with a grey core, and one piece, a large butt-beaker fragment, has the pale orange surfaces used for copies of Gallo-Belgic forms.

The forms are as follows (Brown & Sheldon 1974, fig.2):

- 1 E1-2. Grog.
- 2 form unknown. Grog.
- 3 E2-1. Grog
- 4 E2-1. Grog.
- 5 E1-2. Grog.
- 6 E2-1. Grog.
- 7 E2-1. Grog.
- 8 grass-tempered.
- 9 not in series. Grog.
- 10 grass-tempered.
- 11 grass-tempered.
- 12 (C1-2). Grog.
- 13 G4. Grog.
- 14 B1-1. Grog.
- 15 not in series.
- 16 A1. Grog.
- 17 grass-tempered.
- 18 grass-tempered.
- 19 grass-tempered.
- 20 grass-tempered.
- 21 C1-2. Grog.
- 22 C1-2. Grog.
- 23 G5-6. Grog.

Some plain coarse bead-rim vessels are grog-tempered. These are the type that occur in later 1st century levels in London, HM and grog-tempered.

## HIGHSTEAD (K)

TR 213 662 Zone 5

1 Excavation of a crop-mark complex prior to gravel extraction has produced much 'Belgic' as well as earlier and later material, from ditches on the brow of a hill with extensive coastal views (site B); site A to the SW has Iron Age and Roman but no 'Belgic' (interims, Tatton-Brown 1975-76, 2-3; 1976, 236-7).

2 The F Brent Collection in the BM includes a few vessels from a 19th century gravel pit at Highstead: two Beakers, found 1866 and 1878, and:

BM 1903/11-15/218. E3-5 form; 'with stand, dug out of Highstead gravel-pit, 7/9/66'.

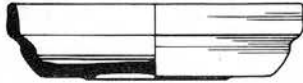

[1528] G1-6. BM 1903/11-15/220. 'F Slater 1889.' Not symmetrical; grog, patchy grey surfaces, burnished dark grey-black inside.

Also present is:

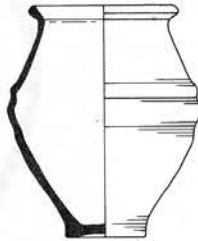

[1531] not in series. BM 1903/11-15/219. 'Highstead Chislet, with remains of bones, 1868.' Cracked and chipped matt buff-grey Roman, with dark grey burnish. Contains a quantity of cremated bone in large pieces. Chislet is at TR 224 644, on the edge of the marshes.

HIGHSTED see SITTINGBOURNE

## HITCHIN (H)

c.TL 19 30 (Grove Mill) Zone 7

1 Grove Mill: 4 circular cavities 'in a line', with levelled floors and smoothed walls, were found in a chalk pit here in November 1889. Ransom (1889-91) records that one was empty, a second destroyed with its pots by the quarrymen; a third held 8 pots at least, which were rescued, and the last contained 'urns of a rather ruder type' with a pair of iron shears and a bronze fibula. However, there are now 12 pots from the Ransom Collection in the BM and CambM, and it is quite uncertain whether all are to be associated together, or if more than one grave is represented.

[985] A1. BM 1915/12-8/1 (=AB 118). Restored, leans over, but neatly made grey grog, patchy surfaces, burnished outside.

[875] E3-5. CambM 23.497 (=AB 123). HM, dark grey gritty, no grog; patchy red-brown-dark grey outside, tooled above line, irregular shaping. Base very chipped and worn, as if stuck to a surface before firing and pulled away.

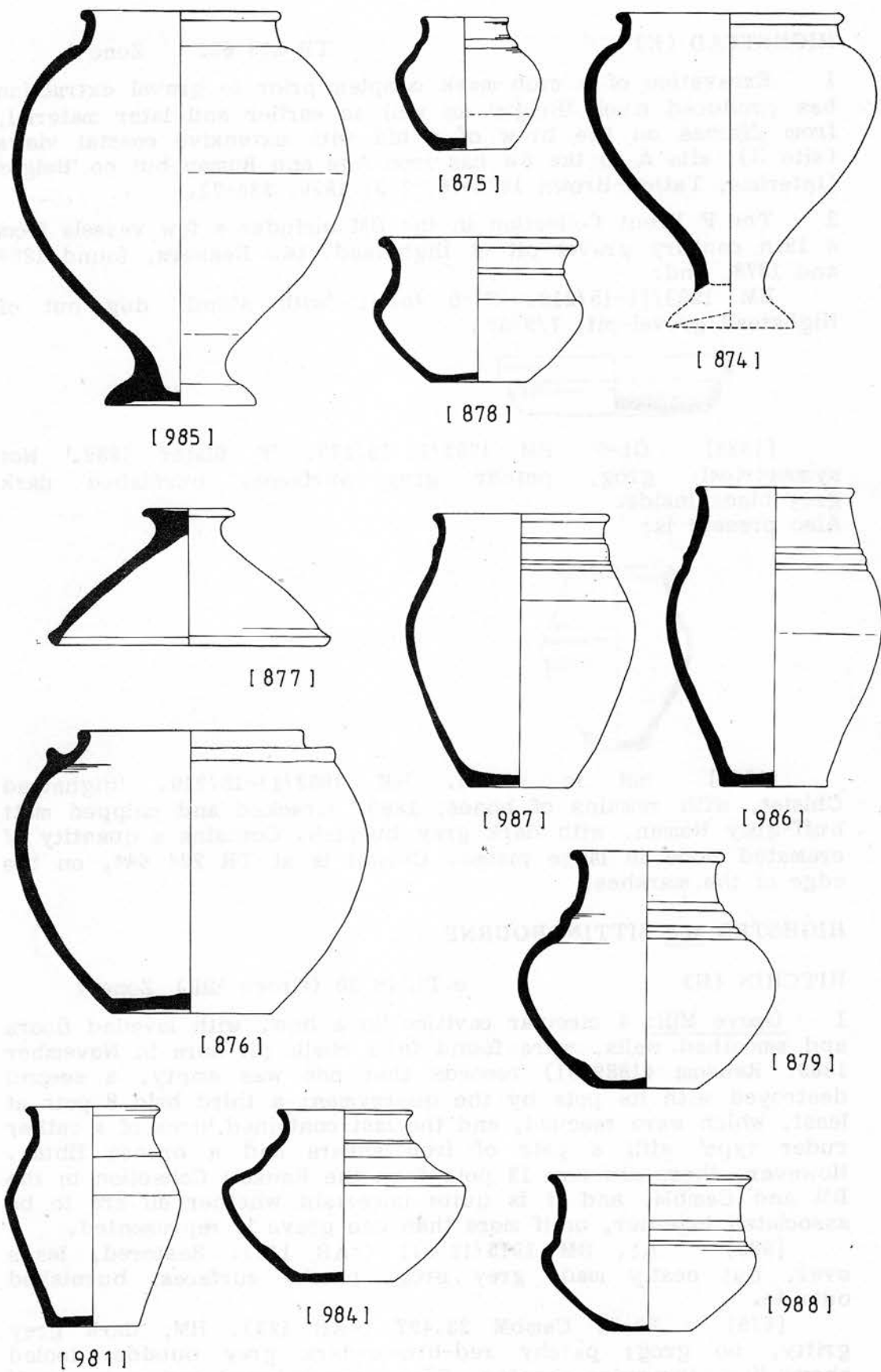

**Fig.45: Pottery from Hitchin, Grove Mill. 1:4**



[878] E2-1. CambM 23.499 (=AB 119). Mended but substantially complete; patchy red-brown-dark grey grog, finished neatly and regularly. Contains 4 large pieces of bone.

[874] A9. CambM 23.494 (=AB 117). Patchy grey grog visible inside, surface scraped; very patchy red-brown outside, large dark grey firing patches, once tooled, now worn. Base missing; plaster foot.

[877] L1. CambM 23.496 (=AB 120). Grey grog, hard and thick, buff below grey-brown surfaces, tooled outside. Inside finished coarsely with perhaps a piece of cloth, now showing wiping lines. Rim not circular, and fits bowl irregularly; complete but for small recent rim chip.

[876] D3-3. CambM 23.496 (=AB 120). Grey grog, patchy grey dull surfaces, smoothed but not burnished. The flange was added by hand as a strip of clay to a globular pot; not very regular. Contains a few burnt bones; complete.

[987] B3-6. BM 1915/12-8/3 (=AB 122). Hard brittle grey-brown grog, red below grey patchy inside and buff-grey patchy outside, some tooling. Broken with a large piece missing.

[986] B3-6. BM 1915/12-8/2 (=AB 124). Very neatly made, grey-brown grog with grey surfaces, tooled roughly below burnished top half.

[879] B3-5. CambM 23.495 (=AB 121). Hard grey grog, neatly made, pink below grey surfaces, flaking in one patch outside, buff patches outside especially towards base; contains large amount of cremated bone and a piece from the neck of a pedestal base, dark grey grog (not [874]).

The above are the pots published by Birchall (1965, 306-7) as the Grove Mill grave-group. Those below were published as extras:

[981] B3-6. BM 1915/12-8/4 (=AB 116). Sandy fabric as in Zone 9, brown with bright orange patches on surface. Complete, wobbly rim, summarily made without burnish.

[984] B3-5. BM 1915/12-8/6 (=AB 115). Grey grog, patchy buff-grey surfaces, no burnish.

[988] E2-1. BM 1915/12-8/5 (=AB 114). Sandy fabric as in Zone 9, pale grey inside, strong orange-brown outside, no burnish. Contains bones.

Fox (1923) and others refer to Grove Mill as Walsworth.

Inside no.875 above is a piece of iron that looks like a very small shield boss: (1:1)

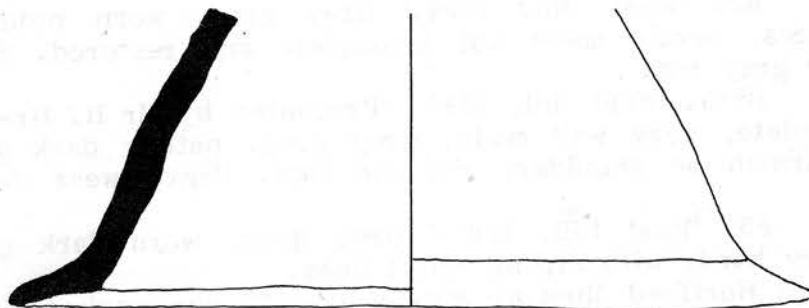

2 Bury Mead. CambM has several vessels from here, also originally in the Ransom Collection:

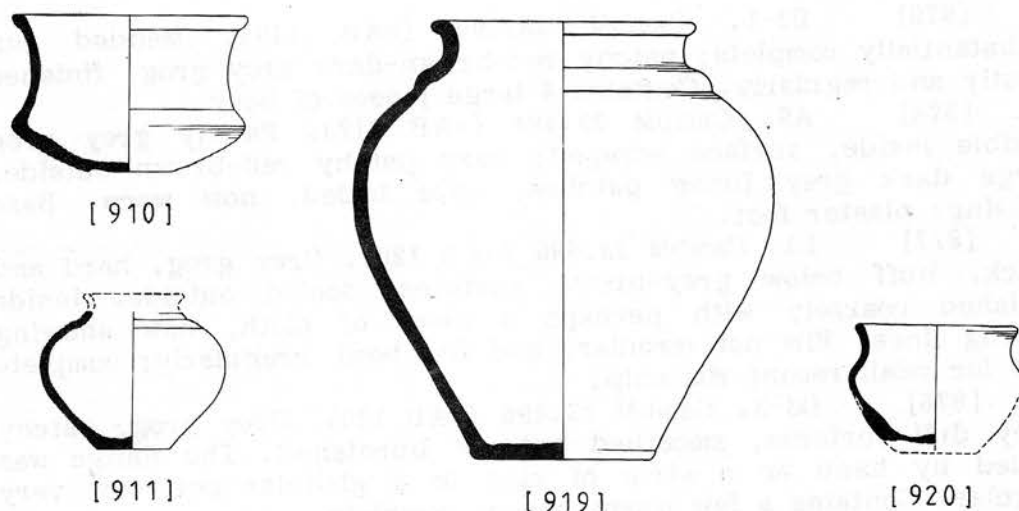

Fig.46: Pottery From Hitchin. 1:4

[910] E1-4. CambM 23.489. Found 1877; contains bones. Sandy, grey-buff, smooth.

[911] E3-5. CambM 23.492. '2 ft deep, 1877.' Contains bones. Sandy, not coarse, grey core and very patchy grey-dark orange surface, as in Zone 9. Grey inside. The museum has two Roman pieces from the same source, not seen, including a flagon (Roman catalogue 23.412, 23.502, Ransom Coll.).

3 'Nr Hitchin' is the only information extant on two other vessels in CambM:

[919] B3-9. CambM 23.491. Ransom Coll. Thick and heavy, complete; some plaster at rim and side. Grey, probably grog.

[920] not in series. CambM 23.421. 'Prob. nr. Hitchin', Ransom Coll. Curious leached fabric, matt smooth grey inside, grey core and brownish outside, split and flaking in lumps. CambM 23.493, 'nr. Hitchin', is labelled Early Iron Age but is a Roman Black Burnished ware jar. CambM 23.488, 'Stondon nr. Hitchin' Ransom Coll., is catalogued as 'Base of large cooking-pot or store-jar. Early Iron Age'.

HODDESDON (H)

c.TL 37 09 Zone 7

[1053] A3. 'West Hill, 1894.' Grey grog, worn reddish-brown surfaces, neatly made but incomplete and restored. Some burnish over grey rim.

[1055] B5-5. 'West Hill, 1897'; 'Presented by Mr H. Brazier 10/5/1.' Complete, very well made, grey grog, patchy dark grey surfaces, burnish on shoulder, rim and foot. Heavy wear under foot.

[1054] F5. 'West Hill, 1897.' Grey grog, worn dark grey surfaces, very hard, with strong wheel lines. These pots, in Hertford Museum with a Drag.27 cup marked 1908, have no circumstantial detail attached, as the records are scanty and confused; they are clearly from burials (the samian cup may be from Welwyn Grange, as are others in the museum with the

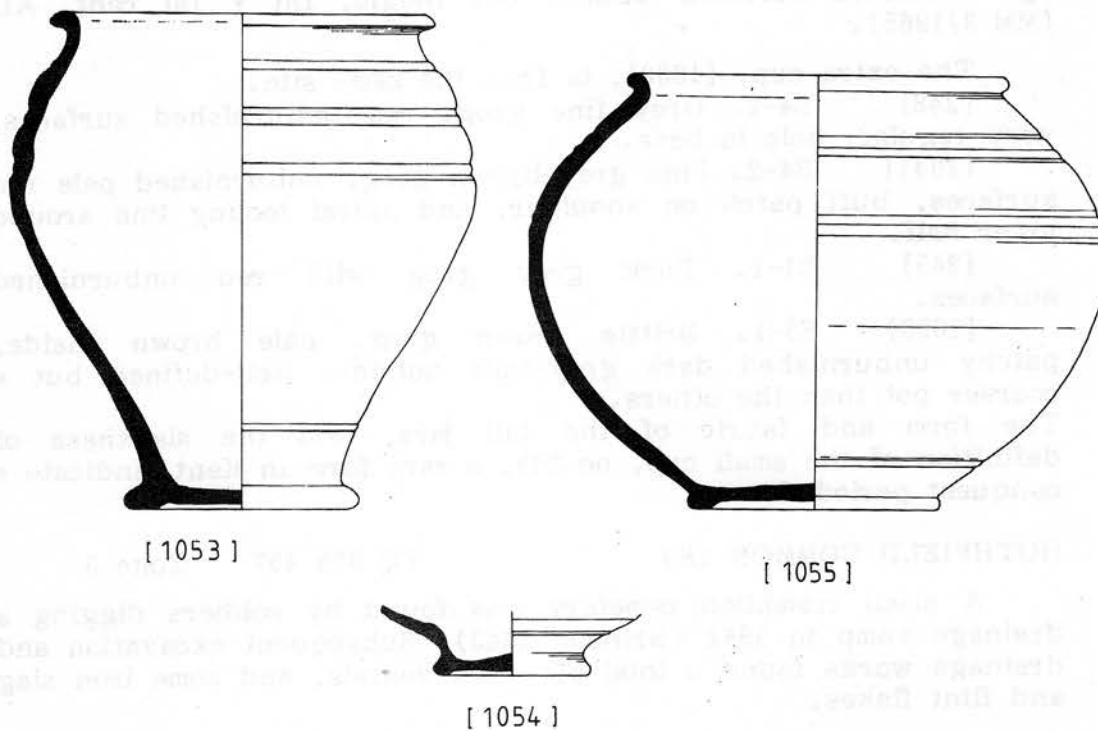

**Fig.47: Pottery from Hoddesdon. 1:4.**

same date). There is no entry for 1901 or Mr Brazier in the Donors Book.

Holmes (1958-61) mentions a local record of 1908, of a site at Cock Lane (TL 363 080) with ditches and storage pits, and some 'roughest country ware' that 'may be Belgic pottery'.

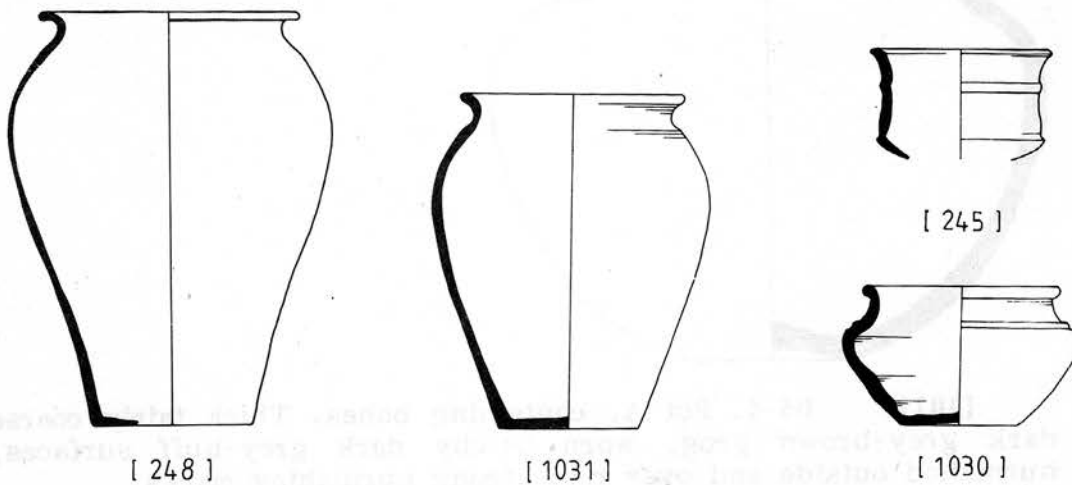

**Fig.48: Pottery from Holborough. 1:4.**

HOLBOROUGH (K)

TQ 697 627

Zone 4

'Two jars and a bowl found with cremation burials at Holborough, Snodland, during quarrying operations, 1964. Given

by Associated Portland Cement Co. Belgic, 1st  $\frac{1}{2}$  1st cent. AD' (MM 3/1965).

The extra cup, [1030], is from the same site.

[248] B4-2. Grey fine grog, red unburnished surfaces, very regular; hole in base.

[1031] B4-2. Fine grey-brown grog, unburnished pale red surfaces, buff patch on shoulder, and spiral tooling line around lower half.

[245] E1-1. Dark grey grog with red unburnished surfaces.

[1030] E3-1. Brittle brown grog, pale brown inside, patchy unburnished dark grey-buff outside; well-defined but a coarser pot than the others.

The form and fabric of the tall jars, and the slackness of definition of the small cup, no.245, a rare form in Kent, indicate a conquest period date.

#### HOTHFIELD COMMON (K)

TQ 975 457 Zone 5

A small cremation cemetery was found by soldiers digging a drainage sump in 1942 (Brinson 1943). Subsequent excavation and drainage works found a total of seven vessels, and some iron slag and flint flakes.

Four burials were apparently represented, although much damaged. 'Many other pits and trenches were dug at this time over Hothfield Common but nothing else was found.' From Brinson's plan it seems that each burial as a rule comprised one larger pot with the bones, and one smaller; the vessels may be grouped as follows:

1

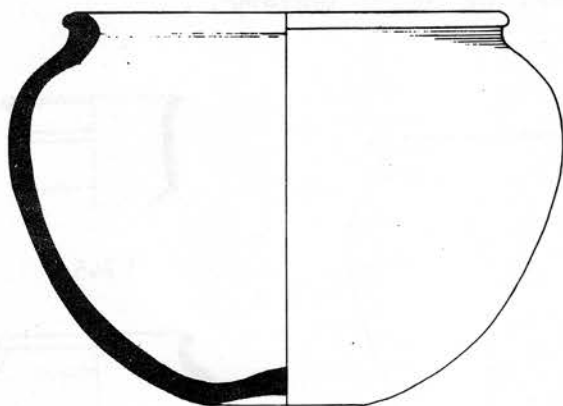

[1011] B5-4. Pot A, containing bones. Thick fairly coarse dark grey-brown grog, worn patchy dark grey-buff surfaces, burnished outside and over rim; strong burnishing marks.

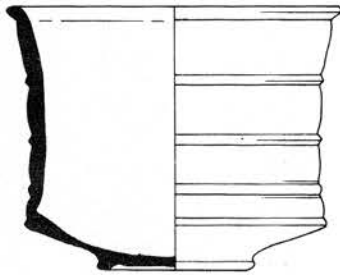

[1010] E1-2. Pot B. Dark grey grog, grey and red inclusions, pink below buff-orange-grey patchy surfaces, burnish outside and over rim. Sharp neat cordons.

2

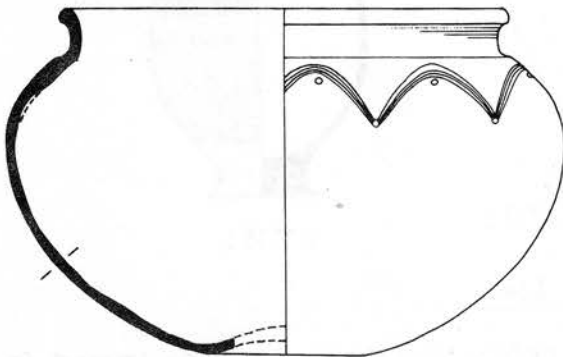

[1012] S3. Pot C; contained bones. Coarse grey grog, very worn dark grey inside, worn dark grey burnished outside, broken especially at widest part; lightly tooled decoration. Large lumps of grey and buff grog.

- with 'Beaker D', in a fragmentary condition; it comprised only a base in a coarse greyish-black ware, 5 ins in diameter (Brinson 1943, 44).

The other two burials were found close together about 2 metres N of the first two.

3 'Urn E', in scattered pieces, was 10 ins tall and 6½ ins in rim diameter, but not described in any detail.

4 'Urn G', Brinson pl.III, a complete jar of B5-5 type, was 'of wheel-turned burnt pottery of the same type as beaker B'. It contained bones and was immediately next to 'Urn F', pl.IV, a rouletted butt-beaker copy of type G5-5, again 'in the same type of pottery as beaker B'.

Brinson provides a plan. The redrawn vessels shown here were given to the Local Secretary of the Kent Archaeological Society, and are now in the possession of Ashford Archaeological Society, but the whereabouts of the others is unknown.