

Gazetteer - Ickwell Bury (B) to Keston (K)

ICKWELL BURY (B)

Tebbutt (1954) noted a pedestal urn in a miscellaneous collection of antiquities at a large house here SW of Sandy: it bore no label, but he assumed it to be a local find. He publishes a

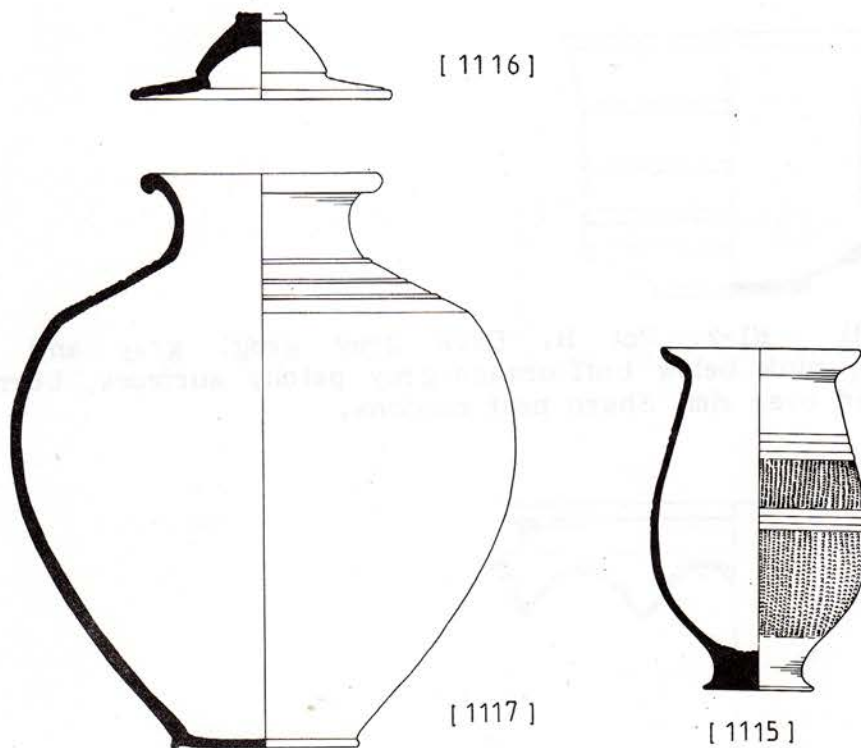

Fig.49: Pottery from Ipswich. 1:4.

photograph of the pot taken before the house was destroyed in a fire in 1937; he thought the collection to have perished, but it is clear from the BM Register that the finds came from Sandy (q.v.) and were given to the BM in 1937.

IPSWICH (S)

TM 153 459 Zone 1

A 1st century Roman cremation, found in 'Fonnereau's Sand Pit' in 1902,, and now known as Dales Road, includes a grog-tempered lid of distinctive form, a rare Camulodunum type. The site is also known as Grimwood's Pit, Norwich Road (J.S. Corder 1903; Moir & Maynard 1933, 258-9).

[1116] L10. IpM 1920/52/13. Same grey grog as at Boxford, with slightly pitted surface. Burnish on outside but not underside; knob lost. Broke off all round at weak point where dome joins flange. Found on top of [1117].

[1117] (B3-8). IpM 1920/52/13. Complete, Roman, buff shows in fork marks at base, patchy buff-pale grey matt surfaces.

[1115] not in series. IpM 1920/52/14. Roman, complete but for chipped rim and foot, matt grey except dark grey highly burnished foot, thin, shows red in chips. Plaster inside foot.

IRCHESTER (N)

SP 917 666 Zone 8

Excavations by the Ministry of Works and various local groups were carried out in 1962-63 during road building where the A45 runs through the site of the Roman town (Hall and Nickerson 1967; Knight 1967). The two published reports do not cover all the work that was done at this time: some more material is in NM, of uncertain origin and all Roman in fabric. Hall and Nickerson's

material is with D.N. Hall; the whereabouts of Knight's is unknown.

The pottery of most interest here is that published by Hall and Nickerson. It is divided into early, middle and late Belgic groups, which do not confirm the pre-conquest dating assigned them by the authors. The excavation was conducted under difficult circumstances and exact stratigraphical relationships were not established.

1 The 'early Belgic' or Iron Ci pottery was mixed with HM 'Iron Age B' pottery in Trench IV. It is a small group of sherds, not all found at the same spot. The lack of Gallo-Belgic forms is no argument for a 1st century BC date; indeed, no.29 can be compared with form Cam.85c, a rough native copy of a girth beaker. Orange surfaces are absent; the non-shelly pieces are described as black and polished. Those in the type series are:

- no.23 D1-4.
- no.24 B3-2. 'Buff.'
- no.27 B3-4.
- no.28 B2-1.
- no.29 G4, small version.

2 The 'middle Belgic' or Cii certainly includes Gallo-Belgic forms, despite the authors' statement to the contrary; but none of the vessels are necessarily post-conquest, except perhaps no.30. This is the group that relates closely to other sites in Zone 8.

- no.30 G5-3. Buff, 'very fine sand'. Pit 121.
- no.32 ?Roman jar. 'Dark buff... gritty.' Pit 121.
- no.33 E1-1, the large local variety; orange. Pit 105.
- no.34 storage jar base, 'red, shelly, and soapy'. Pit 105.
- no.35 G4, orange. Another common local form; unstratified.
- no.36 D2-1, orange. Unstratified.

3 The 'late Belgic' or Ciii pottery contains a good many pieces that are undoubtedly post-conquest. It is not clear whether any of the three brooches, fig.16 nos.1-3, were in direct association with any of the pottery; no.3, like pots 48-62, came from Ditch D2.

Burial I, in Pit 97:

- no.37 G5-3, 'bright red'.
- no.38 (G1-8); 'red, painted dark brown'.
- no.39 F3-4. 'Red, painted dark brown'; contained bones.

This pot is related to G4, with a pedestal.

This grave still has strong native characteristics, but apparently cut into burial II, which has a butt-beaker and jug of non-native fabrics, and a distinctly post-conquest jar. The use of paint is a local trait, found at Odell and Rushden after the conquest.

Burial III: one vessel, no.43: G5-5. Local dark grey with two bands of black paint. Contained bones and found in Pit 110.

Burial IV has Roman vessels derived from native forms such as E1-1 and butt-beakers.

'Domestic wares': most of the forms are distinctly post-conquest. The orange colouring typical of late 'Belgic' forms in the area is now disappearing in favour of sandy grey wares (Hall &

Nickerson 1967, 86) and nos.71-105, a single group (without native forms except storage jar rims) were accompanied by Drag.18 and 29 samian forms.

Nos.48-70 include a few late 'Belgic' forms; different from, and earlier than, the group of nos.71-105. Nos.48-63 were 'a single group found in the undisturbed part of Ditch D2'. Those in the type series or related to it are:

no.53 G4. 'Grey.'
no.59 late butt-beaker of G5-5 form. 'Black... very high polish.'

nos.60-64 shelly jars, 3 of them ledge-rimmed, and one storage jar. Blackened 'pink'.

no.67 (G5-5). 'Blue-grey.' Unstratified.

The pottery published by Knight (1967, figs.8-10) is from the excavation of the Roman town's southern defences and some extra-mural occupation. There is only a small amount of 'late Belgic', none pre-conquest and none of sufficient individual interest for inclusion here. The fabrics are romanised (Knight 1967, 103). The butt-beaker used for a cremation burial in Site A (fig.8 no.1) is very similar in form, decoration and fabric to that from Pit 110 on Hall and Nickerson's site (no.43).

JULLIBERRIES GRAVE (K)

TR 077 533 Zone 5

A group of early Roman burials cut into the lip of the southern ditch of this long barrow in the Stour valley SW of Canterbury were discovered during excavations in 1937 by R.F. Jessup and Wye College (Jessup 1939). Two were inhumations and two cremations, and the pottery is still in the 'Belgic' tradition. It bears strong resemblances to mid-1st century AD pottery from Richborough. Two more burials were noted but left unexcavated, and there were traces of another.

Burial 1: inhumation of a child aged 5-7.

fig.4 no.1 E2-3. 'Light grey.'

fig.4 no.3 G1-6. 'Soft grey.'

fig.2 bronze bracelet.

fig.3 bronze brooch, Nauheim derivative.

Burial 2: inhumation of a young woman.

fig.4 no.2 E1-4. 'Coarse sandy red.'

fig.4 no.4 G1-6. 'Soft grey.' This platter form is characteristic of Zone 5.

Burial 3: partial cremation of a young adult.

no.5 G1-6. 'Hard reddish clay... black varnish.'

no.7 G5-5. 'Hard sandy red... smooth chocolate-coloured slip.'

no.8 B3-7. 'Hard reddish-brown.'

no.11 G3-1. 'Sandy grey.' Potter's mark under base.

no.12 G3-1. 'Hard grey.'

no.13 Cam.144 jug, 'pale buff sandy clay, extremely soft.'

Burial 4: cremation.

no.14 B1-4. 'Hard sandy grey.'

no.6 (G1-1). 'Hard grey clay.' The dark brown 'slip' on these vessels could be a high burnish, which changes the surface colour.

Roman occupation debris found on the SE side of the mound included part of a Drag.37, AD 70-80; a fragment of a glass cup; and some coarse pottery, 'most of which can be dated in the 1st cent. AD'.

no.9 B1-1. 'Hard brown clay.'

no.10 G1-6.

Not illustrated: flint-gritted coarse cooking-pot (a local Iron Age fabric); fragments of a small Roman sandy grey pot; and the '3-ribbed handle of large amphora of bright buff sandy clay'.

KELVEDON (E)

Area of TL 865 190 Zone 1

The Roman town of Canonium was preceded by late Iron Age settlement which has been long known from random discoveries and recently subjected to excavation in advance of building, in the open area between the present village on the London-Colchester road, and the river.

1 In CM is a collection of pottery, Iron Age and Roman, made in the 1930s: CMR 1935-37, pl.XVII:

no.1 A4.

no.3 B3-6.

no.10 C1-2.

Note also the platter fragments, and no.2 which is probably an A5 pedestal base.

2 Also in CM is a large quantity of pottery dug up at Kelvedon by M.J. Campen (1956-1963); much of it is worth illustration, although it is all unstratified. It came, with coins and brooches, from pits and ditches (VCH 1963, 150).

[1457] A1. Coarse grey grog, tooled surfaces.

[1456] A1. Worn grey grog, smooth outside.

[1460] A1. Good red-brown-grey grog, grey smooth surfaces, very worn.

[1459] A1. Good grey-brown grog, smooth tooled dark grey outside, worn reddish inside.

[1458] A4. Hard grey-buff grog, tooled dark grey surfaces, buff inside foot base.

[1461] A5. Very worn red-brown thin grog, grey surfaces.

[1504] B1-1. CM 496.1963. Good grey-brown grog, dark grey surfaces.

[1507] B1-1. CM 496.1963. Grey hard grog, dark grey surfaces, tooled very dark grey outside.

[1497] B2-1. CM 496.1963. Probably wheel-made, fairly hard grey grog, dark grey-brown surfaces, burnished on neck, and tooled decoration below. Extra body sherds from lower body, also with zig zag.

[1498] B2-3. CM 496.1963. Very roughly HM grey-brown grog, patchy dark grey surfaces, rough heavy tooling outside.

[1496] B2-3. CM 496.1963. HM fairly hard grey grog, rough dark grey inside, tooled smooth patchy grey outside.

[1480] B3-1. Romanised grey grog, red sandwich below smooth dark grey surfaces, tooled outside.

[1466] B3-1. Hard romanised blue-grey grog, grey inside, smooth yellow-buff or grey outside. No shine.

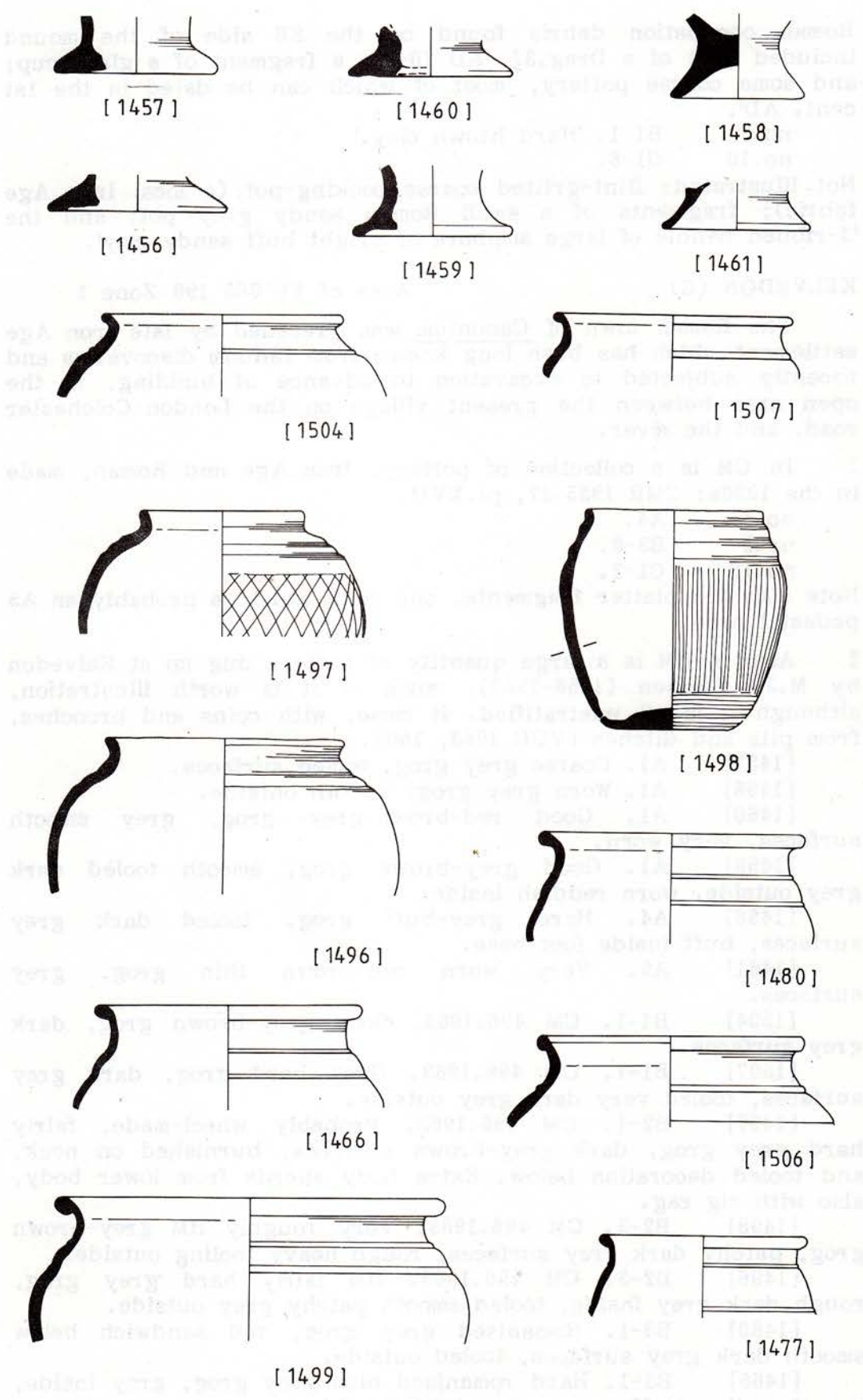

Fig.50a: Pottery from Kelvedon. 1:4

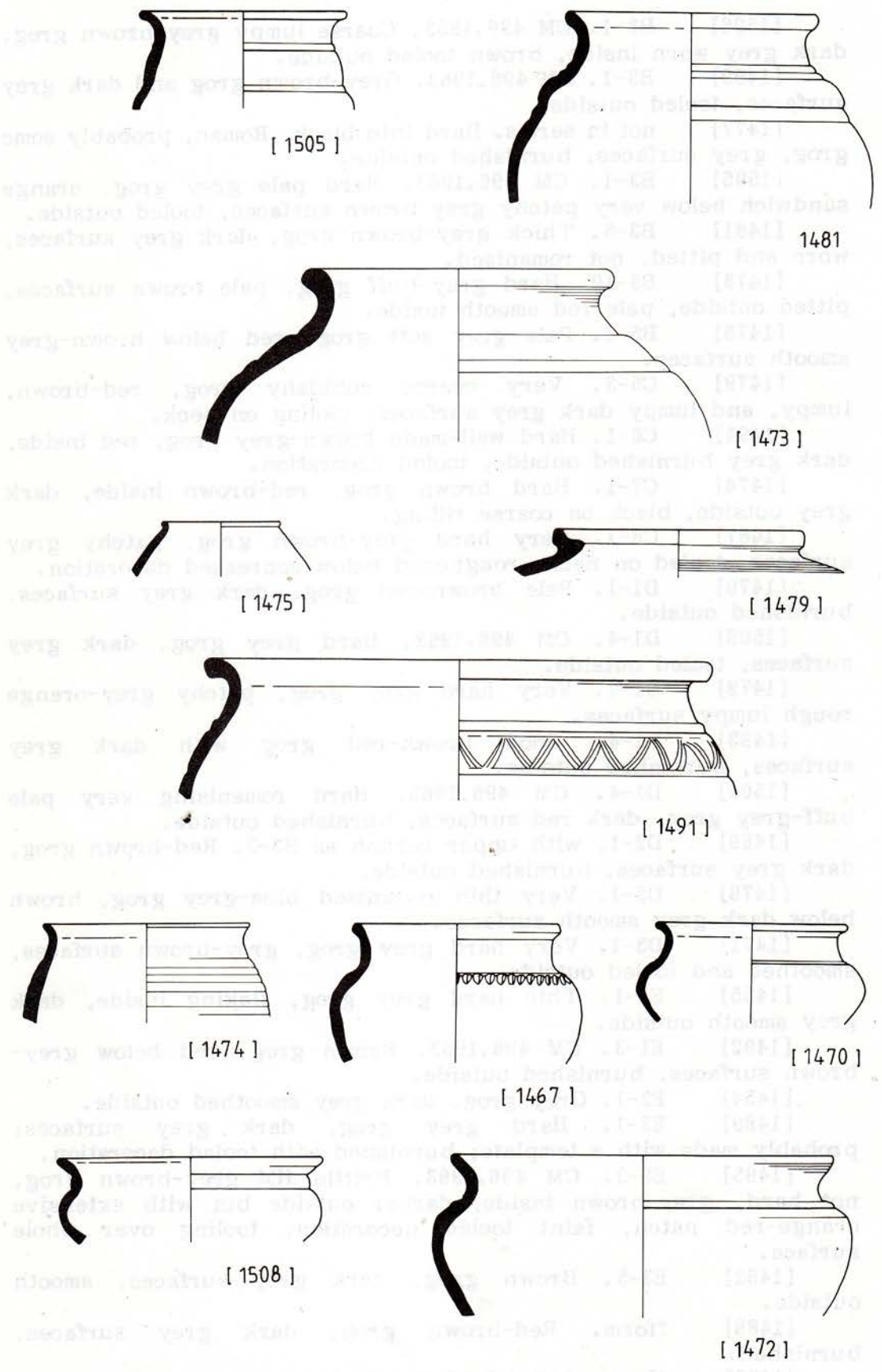

Fig.50b: Pottery from Kelvedon. 1:4

- [1506] B3-1. CM 496.1963. Coarse lumpy grey-brown grog, dark grey worn inside, brown tooled outside.
- [1499] B3-1. CM 496.1963. Grey-brown grog and dark grey surfaces, tooled outside.
- [1477] not in series. Hard thin black, Roman, probably some grog, grey surfaces, burnished outside.
- [1505] B3-1. CM 496.1963. Hard pale grey grog, orange sandwich below very patchy grey-brown surfaces, tooled outside.
- [1481] B3-6. Thick grey-brown grog, dark grey surfaces, worn and pitted, not romanised.
- [1473] B3-10. Hard grey-buff grog, pale brown surfaces, pitted outside, pale red smooth inside.
- [1475] B5-1. Pale grey soft grog, red below brown-grey smooth surfaces.
- [1479] C5-3. Very coarse rubbishy grog, red-brown, lumpy, and lumpy dark grey surfaces, tooling on neck.
- [1491] C6-1. Hard well-made brown-grey grog, red inside, dark grey burnished outside, tooled decoration.
- [1474] C7-1. Hard brown grog, red-brown inside, dark grey outside, black on coarse rilling.
- [1467] C8-1. Very hard grey-brown grog, patchy grey surfaces, tooled on neck, roughened below impressed decoration.
- [1470] D1-1. Pale brown-red grog, dark grey surfaces, burnished outside.
- [1508] D1-4. CM 496.1963. Hard grey grog, dark grey surfaces, tooled outside.
- [1472] D1-4. Very hard grey grog, patchy grey-orange rough lumpy surfaces.
- [1483] D1-4. Good brown-red grog with dark grey surfaces, burnished outside.
- [1500] D1-4. CM 496.1963. Hard romanising very pale buff-grey grog, dark red surfaces, burnished outside.
- [1469] D2-1, with upper cordon as B3-3. Red-brown grog, dark grey surfaces, burnished outside.
- [1476] D2-1. Very thin romanised blue-grey grog, brown below dark grey smooth surfaces.
- [1471] D3-1. Very hard grey grog, grey-brown surfaces, smoothed and tooled outside.
- [1455] E1-1. Thin hard grey grog, flaking inside, dark grey smooth outside.
- [1492] E1-3. CM 496.1963. Brown grog, red below grey-brown surfaces, burnished outside.
- [1454] E2-1. Grey grog, dark grey smoothed outside.
- [1489] E2-1. Hard grey grog, dark grey surfaces; probably made with a template; burnished with tooled decoration.
- [1495] E2-3. CM 496.1963. Brittle HM grey-brown grog, not hard, grey-brown inside, darker outside but with extensive orange-red patch, faint tooled decoration; tooling over whole surface.
- [1462] E3-5. Brown grog, dark grey surfaces, smooth outside.
- [1488] ?form. Red-brown grog, dark grey surfaces, burnished.
- [1490] ?form, but cf. D3-5. Hard grey grog, dark grey surfaces; made with template, burnished.

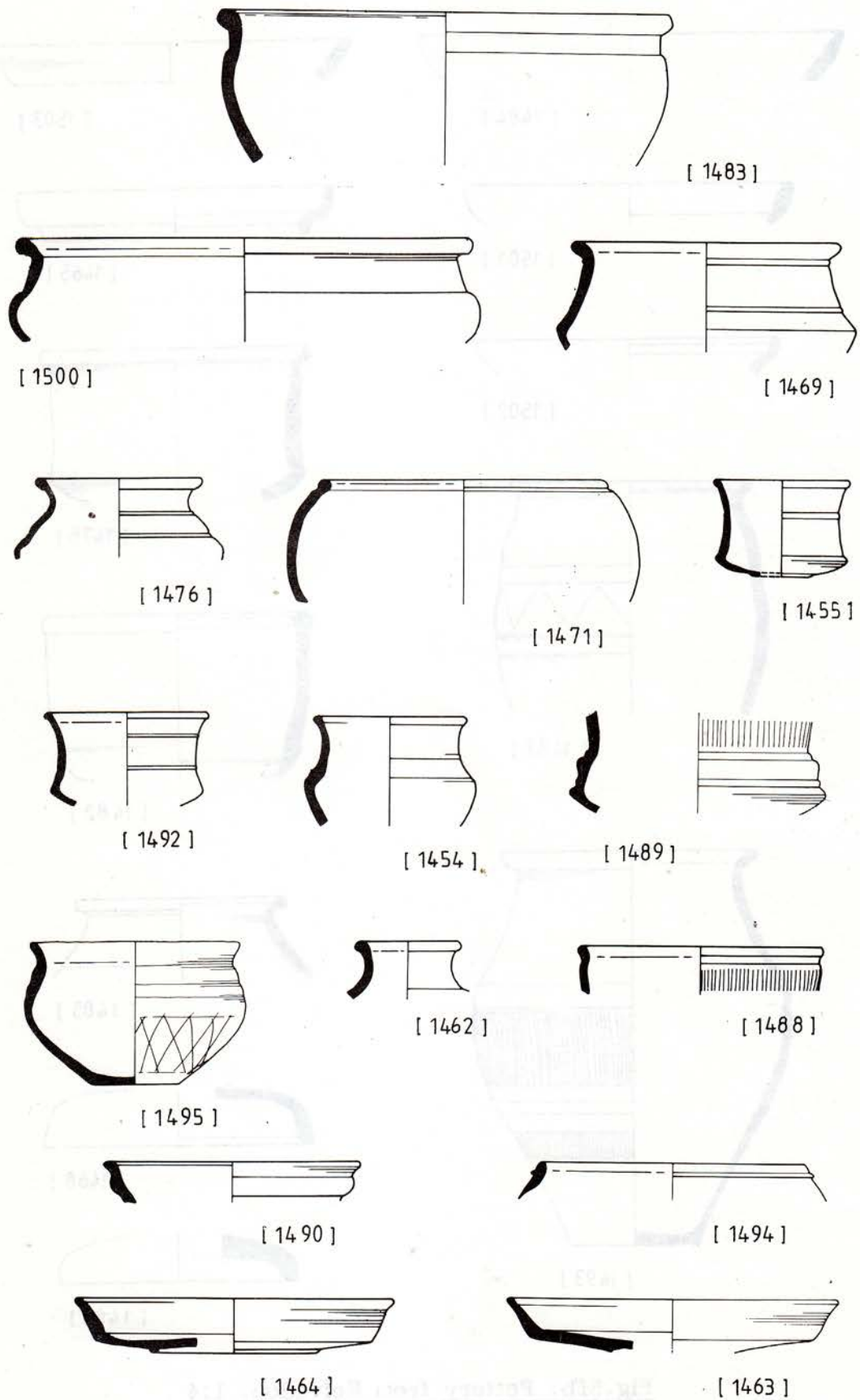

Fig.51a: Pottery from Kelvedon. 1:4

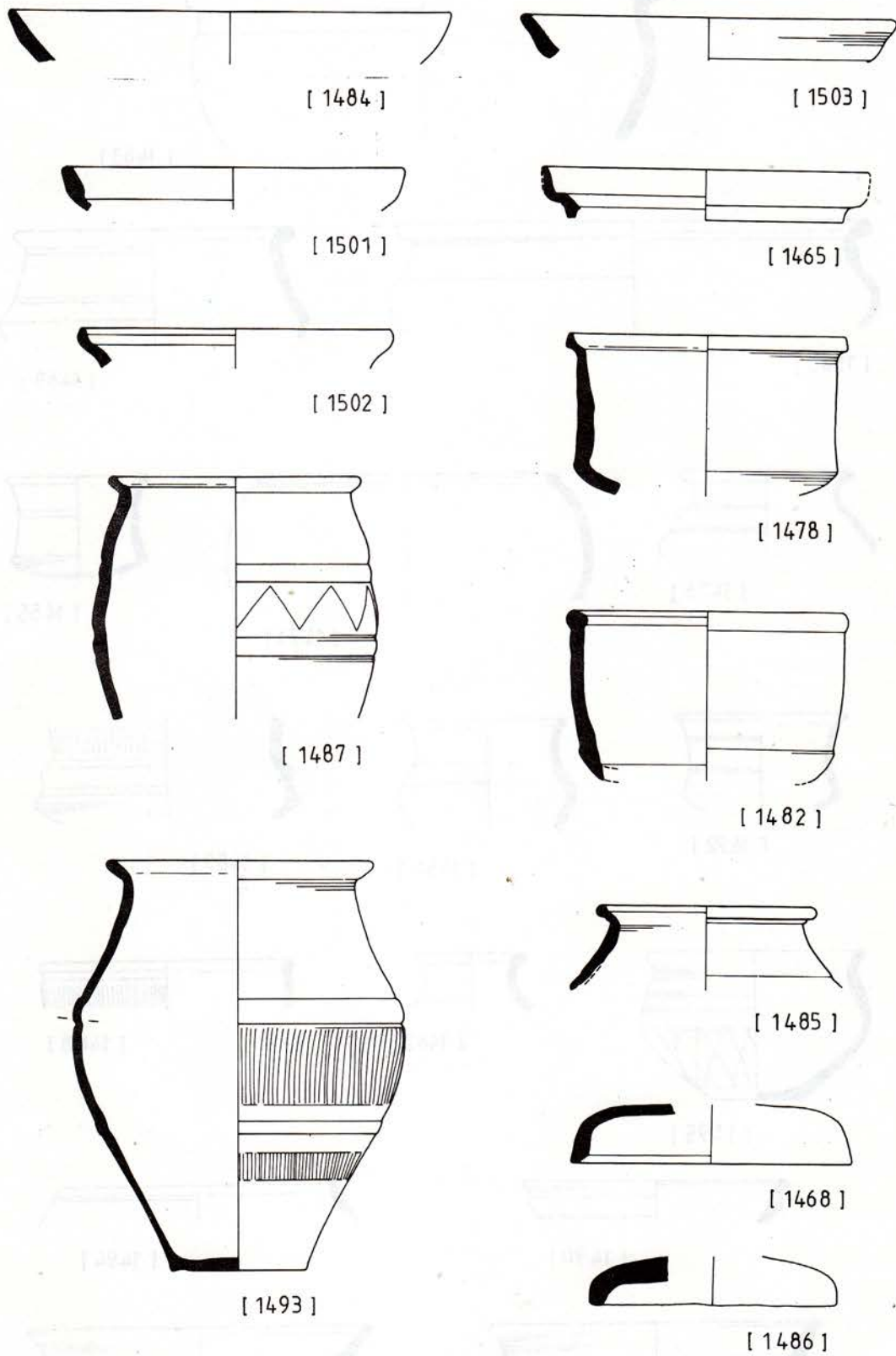

Fig.51b: Pottery from Kelvedon. 1:4

- [1494] ?form. CM 496.1963. Grey grog, brown-red below dark grey-brown surfaces, tooled outside.
- [1464] G1-1. Grey-buff grog, dark grey polished surfaces. Another very similar.
- [1463] G1-1. Hard dark grey grog, patchy yellow-grey smooth surfaces.
- [1484] G1-1. Grey-brown grog.
- [1503] G1-1. CM 496.1963. Orange grog, orange surfaces; sherd only.
- [1501] G1-1. CM 496.1963. Good hard grey-brown grog, dark grey smooth surfaces; sherd only.
- [1465] G1-6. Good grey grog, smooth dark grey surfaces; sherd only.
- [1502] G1-8. CM 496.1963. Hard grey grog, dark grey smooth surfaces. Sherd only.
- [1478] G2-4. Hard dark grey romanised fabric, ?any grog, very patchy yellow-grey surfaces, tooled outside on body.
- [1482] G2-4. Roughly wheel-made, thick coarse grey-brown grog, grey-brown surfaces, rough horizontal burnish outside.
- [1487] G5-2. Red-brown grog, dark grey surfaces, burnish and very faint pattern tooled on outside.
- [1493] G5-5. CM 496.1963. Red-brown grog, dark grey surfaces, burnished outside and with bands of lightly incised lines, done by hand. Now in pieces and with much missing.
- [1485] G5-6. Thin grey grog, dark grey surfaces, burnished outside.
- [1468] L3. Grey grog, dark grey surfaces, burnished outside only.
- [1486] L3. Very roughly HM, very hard, sandy, ?any grog; grey with pebbles etc.

3 The recent excavations by K. Rodwell, and by the County Unit, have shown the pre-conquest settlement to have been prosperous (brief reports in *Britannia* 1971-73; plan, 1974, 443; K. Rodwell and W. Rodwell 1975; plans of rectangular huts within enclosures, K. Rodwell 1979, 329, and mid-1st century kilns and ditch, 331). The rectangular huts were accompanied by briquetage, a Dressel IB amphora fragment, Gaulish and potin coins, and typologically early pottery such as the following (W. Rodwell 1976a, 228-232):

- 8 C7-3.
- 9 C2-2
- 31 B2-1.

Finds of later date included more briquetage, Gallo-Belgic and Arretine wares, amphorae and glass beads, and a unique stamp-decorated vessel, shown in W. Rodwell 1973, fig.1 (and with more sherds, W. Rodwell 1976a, fig.39). The form is related to vessels found in Gaul (see Lobjois 1966, 23, and pl.9) of late La Tene date, as well as to Italian vessels: cf.G2-1. The County Unit excavations confirm the relationship of the Kelvedon pottery with that of other local sites, and Camulodunum in particular.

4 A cemetery found on the Durward's Hall estate (c.TL 846 169) between Kelvedon and Witham in the 1850s is now represented only by a small carinated cup and a bronze brooch in the BM; several other pots had been found containing burnt bones, and a

'considerable' number of bronze coins (Tite 1870; see VCH 1963, 150 - 'Dorward's Hall').

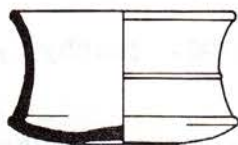

[61] E1-1. BM 70/12-29/1. Orange grog with worn dark grey surfaces, burnished once. The brooch, a Colchester with perforated catchplate, is illustrated by Bushe-Fox (1925, pl.14, no.13); Stead (1976, 413) points out that the drawing is inaccurate, as the brooch has side-wings.

KEMPSTON (B)

TL 027 483 (Hill Grounds) Zone 7

Pottery from burials was collected many years ago; many vessels are in BedM but some went elsewhere or disappeared into private collections. Of those illustrated by Simco (1973, fig.5) nos.22-31 comprise a group found at Hill Grounds 'in a circle' in 1913, possibly a composite grave like those from Aylesford.

- no.22 E1-3. Grog and some sand.
- no.23 not in series. Gritty pale grey Roman.
- no.24 E3-7. Slightly gritty, grog.
- no.25 (G1-1). Gritty, ?some grog.
- no.26 post-conquest, sandy: Cam.243-6.
- no.27 (G5-5). Sandy, orange.
- no.28 G5-5. Dark grey grog, some grits.
- no.29 dark grey sandy Roman.
- no.30 E3-7. Sandy, very hard.
- no.31 E2-1. Complete, probably grog-tempered.

As a group, these are post-conquest and show the range of forms and fabrics of the area. The other vessels from Hill Grounds have lost their associations; nos.32-36 were found between 1863 and 1913.

- no.32 (G5-5). Fine sandy.
- no.33 (G5-5). Sandy, fine, well made, dark grey inside.
?Burnt.
- no.34 (G5-4). Pale grey core, very hard, gritty. Possibly some grog, but almost complete.
- no.35 D1-1. Sandy.
- no.36 A9. Grog.

23 others were found in 'a saucer-shaped depression' during gravel-digging in 1889 (Simco 1973, 18; Elger 1889-91, but no illus.).

Nos.37-50 illustrated by Simco are from Kempston, found between 1910 and 1937, but have no precise provenance or associations (all BedM).

- no.37 G1-9. Grey grog, burnished.
- no.38 Cam.22. Complete, early Roman.
- no.39 B3-8. Probably grog.
- no.40 E3-7. Gritty.
- no.41 E1-2. Not seen.
- no.42 B1-5. Grey Roman.
- no.43 E3-7. Grog.

- no.44 E3-5. Not seen.
 no.45 E3-6. Complete, sandy and very hard. Might have some grog.
 no.46 E2-3. Black, probably no grog.
 no.47 B2-4. Thick, black, no grog, and like no.46 could be early. No sign of the 'dimples'.
 no.48 (G1-6). Sandy Roman fabric.
 no.49 (G1-6). Not seen.
 no.50 G1-6. Grog.
 BedM also has the following:

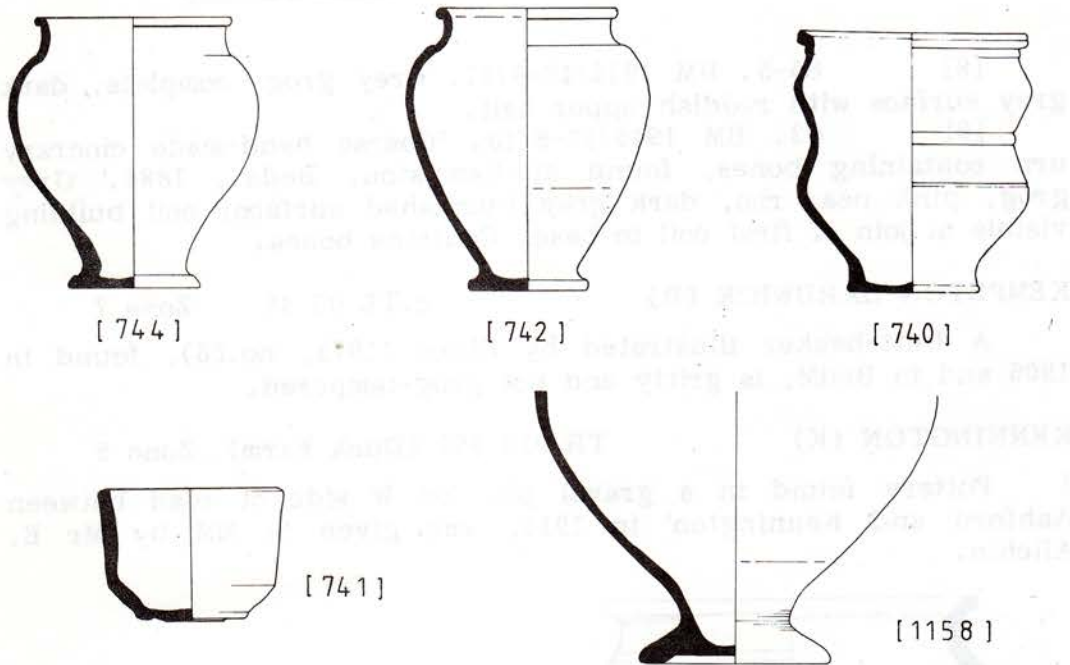

Fig.52: Pottery from Kempston. 1:4

[744] A8. BedM 3356 (1904). Gritty grey grog, worn reddish-buff surfaces.

[742] A8. BedM 3355 (1914), J.W. Lack Coll. (see Kennett 1971a). Complete but for rim chip, feels like grog but probably some sand, dark grey surfaces, burnished.

[740] G4. BedM 3315 (4.4.1913). Dark grey grog, pale buff surfaces, grey patches on outside, burnished.

[741] not in series. 1913. Sandy, complete, no visible temper; pale orange surfaces with grey patches, burnished outside.

[1158] A1. BedM 3661, '?Kempston.' Hard grey grog, dark grey surfaces, some burnish on foot. Hawkes and Dunning (1930, 325) mention a pedestal urn which may be this pot.

The Ransom Collection in the BM has another two vessels:

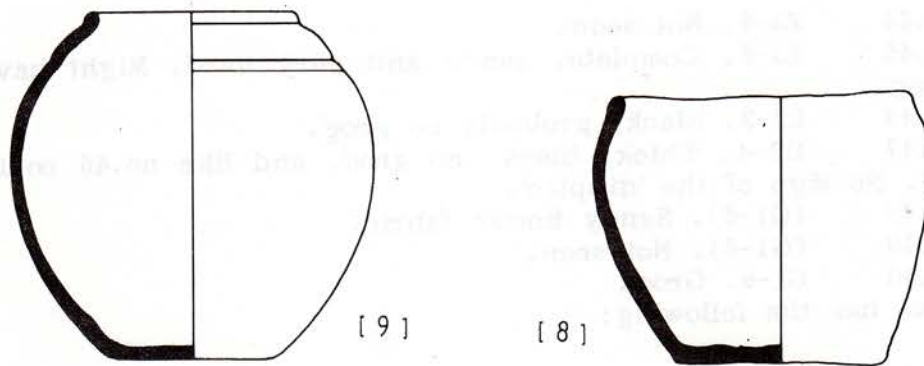

[9] B5-5. BM 1915/12-8/11. Grey grog, complete, dark grey surface with reddish upper half.

[8] C3. BM 1915/12-8/10. 'Coarse hand-made cinerary urn containing bones, found at Kempston, Beds., 1884.' Grey grog, pink near rim, dark grey burnished surface; coil building visible at join of first coil to base. Contains bones.

KEMPSTON HARDWICK (B) c.TL 03 44 Zone 7

A butt-beaker illustrated by Simco (1973, no.56), found in 1906 and in BedM, is gritty and not grog-tempered.

KENNINGTON (K) TR 013 459 (Duck Farm) Zone 5

1 Pottery found in a gravel pit, 'on W side of road between Ashford and Kennington' in 1914, was given to MM by Mr E. Allchin.

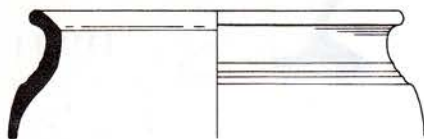

[973] B2-1. Two rim sherds, one burnt white-brown; grey grog, some white lumps, not gritty but hard and precise,

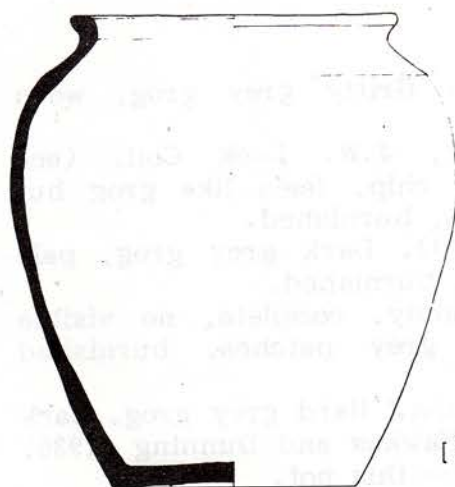

[1170]

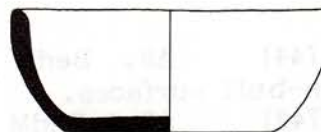

[1171]



[1172]

Fig.53: Pottery from Kennington. 1:4.

dark grey surfaces, burnished rather brown outside and over rim, neck rather irregular shallow rippling. A grog-tempered rilled sherd is part of the same find.

2 Duck Farm: a cremation in a native jar with native copies of a Gallo-Belgic dish and bowl, found in a private garden (MM 57.1963; Kelly 1963a).

[1170] not in series. HM jar, coarse black fabric with sharp-edged white lumps, patchy coarse orange surfaces with blackening around shoulder and rim.

[1171] G1-10. Probably HM, uneven shape, buff-brown coarse grog, not very hard; patchy buff-grey surfaces, smoothed, very even inside, very rough outside: grog lumps pulled out of pitted surface, with wipe marks.

[1172] G1-11. Probably HM, some coarse buff-brown grog, buff inside, fairly smooth but not shiny; buff-grey outside, roughly burnished.

KENSWORTH (B)

c.TL 03 19 Zone 7

Much of a large jar from here is in BedM, without circumstantial detail. Kensworth is S of Dunstable.

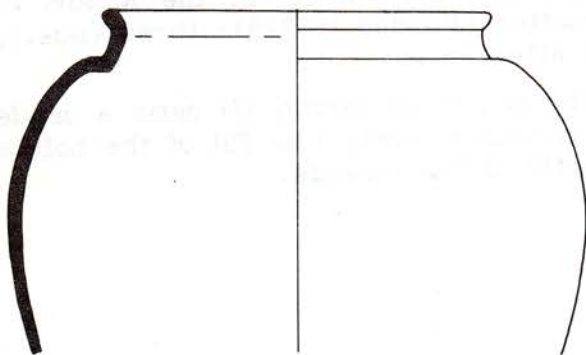

[745] B1-2. BedM 3655. Grey coarse grog, dark grey surfaces, burnished outside. In pieces; well finished.

KESTON (K)

Zone 3

1 The 1st century and 'Belgic' pottery published by Piercy Fox from the extensive Iron Age and Roman settlement at Lower Warbank (TQ 540 745) is Flavian, found with samian of c.AD 85, and typologically post-conquest (Piercy Fox 1955, 109, and fig.9). Investigation is continuing (Philp 1976b).

2 The hill-fort known as Holwood or Caesar's Camp (TQ 42 64) is of early Iron Age date; 'Belgic' sherds [have been found on] a terrace about a quarter of a mile lower down the south-eastern slope of Holwood Hill' (Piercy Fox 1958).

I have not seen any 'Belgic' wares from Keston, and the site is well to the W of the usual distribution of grog-tempered 'Belgic'.

3 Leafy Grove burials (TQ 4136 6388). Five groups were found dated AD 50-120 but including 'Patch Grove' jars of the 'Belgic' tradition (Philp 1973, 94).

Burial 1: a base, 'Patch Grove ware'; no other objects.

Burial 5: no.258, a B3-8 jar, containing bones, in grey-brown 'Patch Grove ware'; with a poppy beaker; a samian cup, Drag.46, and a Drag.18 platter; and a buff flagon: c.AD 70-100.

The pots in the other 3 burials were all of Roman forms.