

Gaetter - Langdon Hills (E) to Lullingstone (K)

LANGDON HILLS (E)

TQ 677 862 Zone 2

Indications of banks and ditches have been observed on this prominent ridge overlooking the Thames bank. Recent machine disturbance resulted in the collection of some flint-gritted sherds and one fragment of probably late Iron Age or early Roman date (C. Couchman 1976, 152). It is described as an imitation TN platter, but it seems narrow and deep; it is too small a fragment to be certain.



[1045] Thurrock Mus.2339. Only a scrap: buff matt fabric, grey surfaces, imitating TN.

LANGENHOE (E)

TM 017 167 Zone 1

A group of Red Hills here was the subject of the Report of the Red Hills Exploration Committee (Reader 1907-9): three (nos. I, III and VI) were given special attention.

From a 'hollow' beneath the centre of mound III came a crude pedestal urn and a decorated omphalos bowl. The fill of the hollow was dark clay, not the red 'earth' of the mounds.

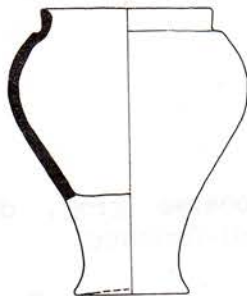

[1141] A6. CM, not marked. Reader op.cit., fig.8B. Much restored, inside plugged with plaster. Crude, HM, dark grey crumbly fabric with grog and grits, some flint lumps; rough vertical tooling outside. Reader shows the base to be plain and hollow inside; the foot is not completely flat.

Elsdon (1975, fig.13, 1) gives a drawing of the omphalos bowl and its stamped and incised decoration. Crude HM copies of pedestal urns are known elsewhere (from Boxford and Mucking, for example). The 'hollow' was apparently a natural hole in the ancient surface of the saltings, and much of the pottery from the site came from this hole in association with the pedestal urn and omphalos bowl (Reader 1907-9, 28), 'the greater part being of a cruder nature than that of any other mound yet explored'. It is clear, however, that some of this 'cruder' HM earlier Iron Age pottery was found in the red earth layers above the hole, and

some well-developed 'Belgic' pieces were in the hole (*ibid.*, 29, and fig.9).

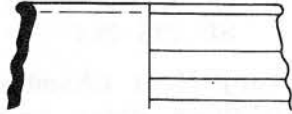

[115] B2-2. From the 'hole' (Reader fig.9 no.11). Hard pale grey romanised, grog, pale grey surfaces, tooled on outside.

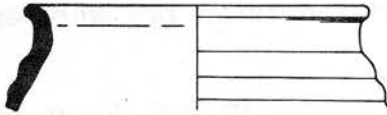

[114] B2-1, 'just above in the red earth' (Reader fig.9 no.14). Hard dark grey romanised grog, burnished outside.

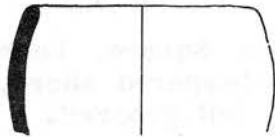

[117] not in series. From the red earth, 1 foot deep. (Reader fig.9 no.7). Hard grey, some burnt out vegetable temper; rough grey inside, buff-grey smooth outside.

Fig.9 no.12 is with these sherds in CM, and is apparently Iron Age, and found in the red earth. Fig.9 no.13 is also from the mound: this is a Cam.258 or C4 form, common in Kent but not in Essex until after the conquest; the fabric is hard grey Roman. The briquetage from the hollow is also described as different from that in the red earth. There seems to be some distinction to be made between hollow and mound deposits, but on the evidence as it stands I would not wish to use it as a clear stratigraphical pointer for dating.

The other site that yielded recognisable pottery was Red Hill I. Sherds from its layers are shown in Reader's fig.7, nos.1-9, and apart from no.1, of uncertain date, they could all be 'Belgic' scraps: a couple of coarse rims, two plain everted rims, a rilled sherd (rare in Essex until after the conquest), two base scraps, and one more substantial rim:

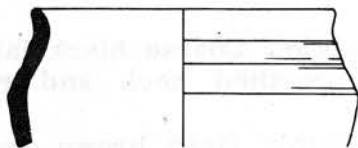

[118] B2-1. Reader fig.7 no.7. Hard dark brown-grey gritty fabric, smooth outside.

See under Goldhanger for Red Hill X, which has early Roman pottery. The Langenhoe pottery found by Reader is characteristically 'Belgic' for the most part, with some Iron Age sherds and a few that appear to overlap the conquest. The Committee found much briquetage but no structural evidence, and

the pottery is essentially unstratified and mixed. Other excavated Essex Red Hills have similar problems.

LEIGHTON BUZZARD (B)

SP 926 264 Zone 7

Grave 57 from Anglo-Saxon cemetery II at Chamberlains Barn, excavated in the 1930s, contained, besides glass and metalwork, two pots which are evidently of late 'Belgic' and early Roman date (Hyslop 1963, fig.18). Other Iron Age sherds were found amongst the excavated material but 'this is the only grave in which large portions of the same vessel occur' and these two were apparently redeposited.

a B1-5. Grey grog, burnished.

b Cam.28 platter, now in pieces, in red Roman ware. The holes were apparently for mending.

LM 178/14157.

LENHAM (K)

TQ 898 522

Pottery from R.H. Goodsall, The Square, Lenham, in MM, comprises Roman wares and one grog-tempered sherd, but this is hard and romanised, and not cordoned but grooved.

LETCHWORTH (H)

TL 235 337 Zone 7

1 A fine cordoned pedestal urn, containing calcined bones and a bronze strap-link, was found by gravel diggers in 1913 (Craske & Smith 1914). Westell (1926, 276) noted that he knew of no further discoveries in the gravel pit.

[733] A3. Well made grainy brown-grey grog, brown-grey smooth surfaces, unburnished. Foot half broken. Local parallels at Sandy and Ravensburgh, but this is larger.

2 Highfield (c.TL 208 327? - Holmes 1958-61, 97). Pottery found on the ridge near Wilbury Hill during sand digging c.1939 is described as 'Belgic', with some samian and a bronze brooch (Westell 1939, 322). LeM has a quantity of Highfield pottery dated 1955, from several features; it is nearly all Roman, except for that from HF V.1, substantial grog-tempered vessels. A few grog-tempered sherds are bagged with the Roman pottery, most of which is in small pieces. V.1 seems to have included only 'Belgic' pots except for one very sandy grey Roman base.

[731] B3-8. Grey grog, smooth surfaces, burnished over rim.

[727] C7-1. HF V2, 'late Belgic'. Coarse black fabric with much red grog, black surfaces, burnished neck and rim, neat incised lines, wiped beneath.

[728] E1-2. Hard, heavy, highly fired brown-grey grog, worn black inside, dark grey smooth outside. Originally burnished black on outside.

[730] D1-1. Hard grey grog, dark grey surfaces worn to pink on lower inside, once tooled and burnished outside. Hole drilled after firing.

3 A box in LeM marked L'W UK 1 (Unknown) contains pottery of late 'Belgic' and early Roman forms. As well as coarse combed grog-tempered sherds the 'Belgic' includes a thick platter copy

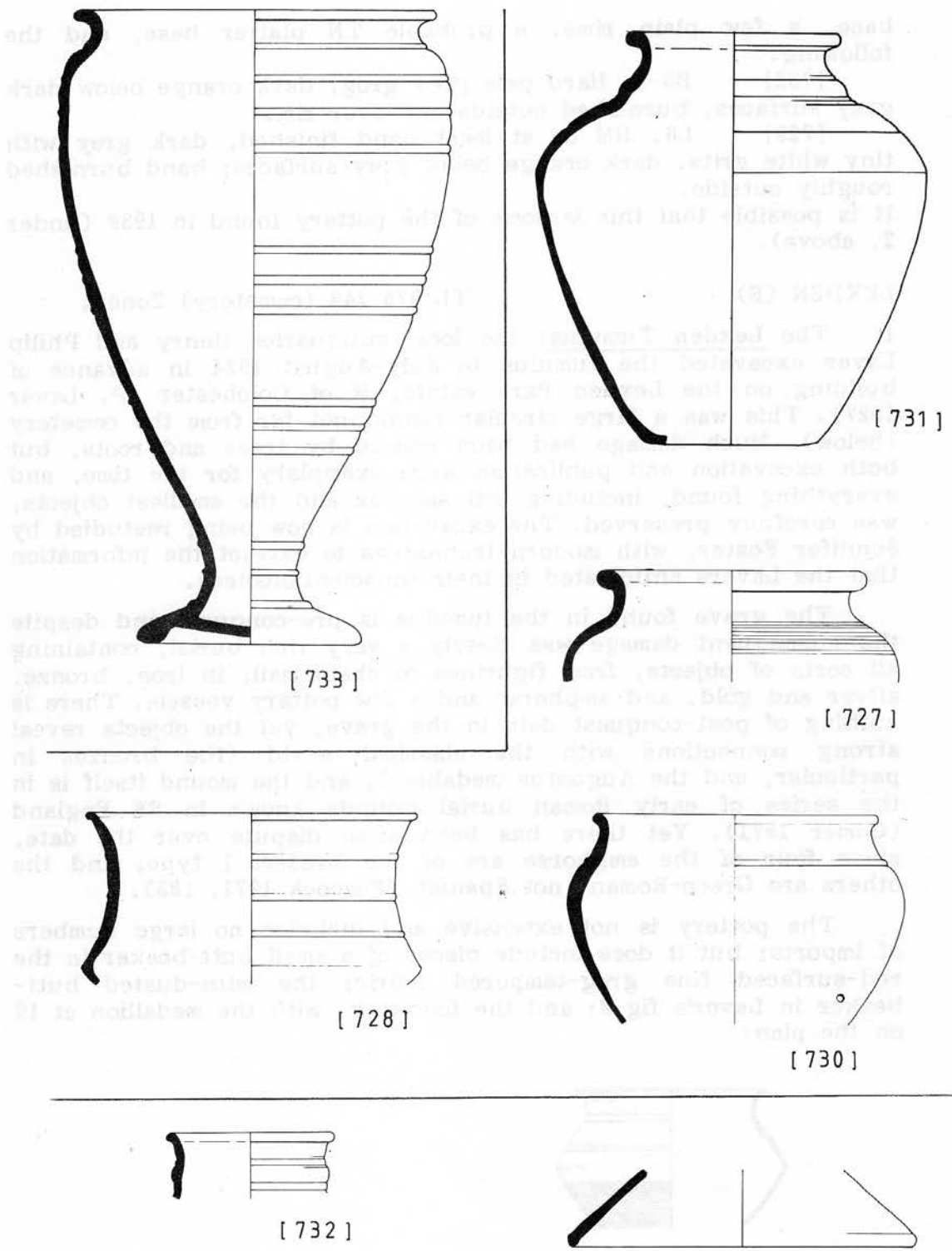

Fig.54: Pottery from Letchworth. 1:4

base, a few plain rims, a probable TN platter base, and the following:

[732] B3-2. Hard pale grey grog, dark orange below dark grey surfaces, burnished outside and over rim.

[729] L6. HM or at least hand finished, dark grey with tiny white grits, dark orange below grey surfaces; hand burnished roughly outside.

It is possible that this is some of the pottery found in 1939 (under 2, above).

LEXDEN (E)

TL 975 248 (cemetery) Zone 1

1 The Lexden Tumulus: the local antiquaries Henry and Philip Laver excavated the tumulus in July-August 1924 in advance of building on the Lexden Park estate, W of Colchester (P. Laver 1927). This was a large circular mound not far from the cemetery (below). Much damage had been caused by trees and roots, but both excavation and publication were exemplary for the time, and everything found, including soil samples and the smallest objects, was carefully preserved. The excavation is now being restudied by Jennifer Foster, with modern techniques to extract the information that the Lavers anticipated in their conscientiousness.

The grave found in the tumulus is pre-conquest and despite the subsequent damage was clearly a very rich burial, containing all sorts of objects, from figurines to chain mail, in iron, bronze, silver and gold, and amphorae and a few pottery vessels. There is nothing of post-conquest date in the grave, yet the objects reveal strong connections with the classical world (the bronzes in particular, and the Augustus medallion); and the mound itself is in the series of early Roman burial mounds known in SE England (Gomer 1971). Yet there has been some dispute over the date, since four of the amphorae are of the Dressel 1 type, and the others are Greco-Roman, not Spanish (Peacock 1971, 183).

The pottery is not extensive and includes no large numbers of imports; but it does include pieces of a small butt-beaker in the red-surfaced fine grog-tempered fabric; the mica-dusted butt-beaker in Laver's fig.2; and the following, with the medallion at 19 on the plan:



[989] D2-1. Laver pl.LII, fig.1. Fine grey-brown grog, pink below dark grey surfaces; burnished finely on outside and over rim, very shallow rilling on lower half; very thin and only a few pieces survive.

This is not an early specimen of the form: it is thin and beautifully made, and cannot date before the later pre-conquest period, from c.AD 25, perhaps, onwards.

2 The cemetery. Iron Age and Roman burials are known in some numbers from housing development since the early part of this century; published references are scattered and incomplete. Hull included most in his Inventory of Colchester burials, unpublished in CM, and Philip Crummy has compiled an unpublished survey of the whole Lexden cemetery. The nucleus is in St Clare Road, a little NW of the tumulus. Problems remain over the associations of some burial groups, as few were properly excavated; the relevant groups are included here in order of accession in CM with what information can be gleaned from the Registers. Roman graves are not included; nor are isolated finds of amphorae, of which there are several (Peacock 1971, 183-4).

(1) Mirror grave: CM 639-647. 1904 (Fox and Hull 1948). With the mirror, on the N side of Lexden Road, were found (figs.8 & 9):

1 bronze bowl, with bronze handle: cf. the Welwyn handle (from the site of the 1906 burials: C. Hawkes 1935. This also has red enamel studs).

2 bronze pin, unparalleled.

3 A1. Grog-tempered.

4 B3-5. Grog-tempered.

5 E2-2. Grog-tempered.

6 D3-5. Grog-tempered.

6a L4. Grog-tempered.

7,8 Cam.131 jugs, imported: red, mica-dusted.

(2) CM 638.1904, purchased by the Hon. Curator; apparently not part of the mirror grave. A1.

(3) Lexden Park, 15 December 1908: CM 1756-1761.1909, all 'found together' according to the Register. Hull's group 174.

[991] A2. 1756.1909 (=AB 189). Grey grog, grey-brown surfaces, burnished outside. Most of rim and much of shoulder missing. Lower inside surface obscured by plaster but not inside base.

[1075] A2. 1757.1909 (=AB 190). Complete but for chipped foot and plaster plug in side. Usual grey-brown grog, burnished outside: a good pot.

[992] A2. 1758.1909 (=AB 188). Grey grog, grey-brown surfaces, inside obscured by restoration; dark grey burnish outside, very worn foot but complete. Rim survives only as a sliver.

[833] L4. Lid of 1759.1909 (=AB 208). Grey soft grog, brown-grey surfaces, burnished; knob and interior top are plaster.

[831] D3-4. 1759.1909 (=AB 208). Grey grog, burnished greeny-grey outside; inside lined with plaster. Distorted but perhaps due to restoration.

[1538] L4. 1760.1909 lid. Now chipped and damaged but mostly complete; good wheel-marks. Grey-brown grog, remains of burnish on knob.

[1539] F3-2. 1760.1909. Chipped, foot not quite symmetrical; good grey-brown grog, tooled darker surface chipped to pink at rim.

[1064] E3-2. 1761.1909. Grey-brown grog, patchy worn grey-brown surfaces, burnished outside.

Other pottery from the Lexden Park Estate found also in 1908:

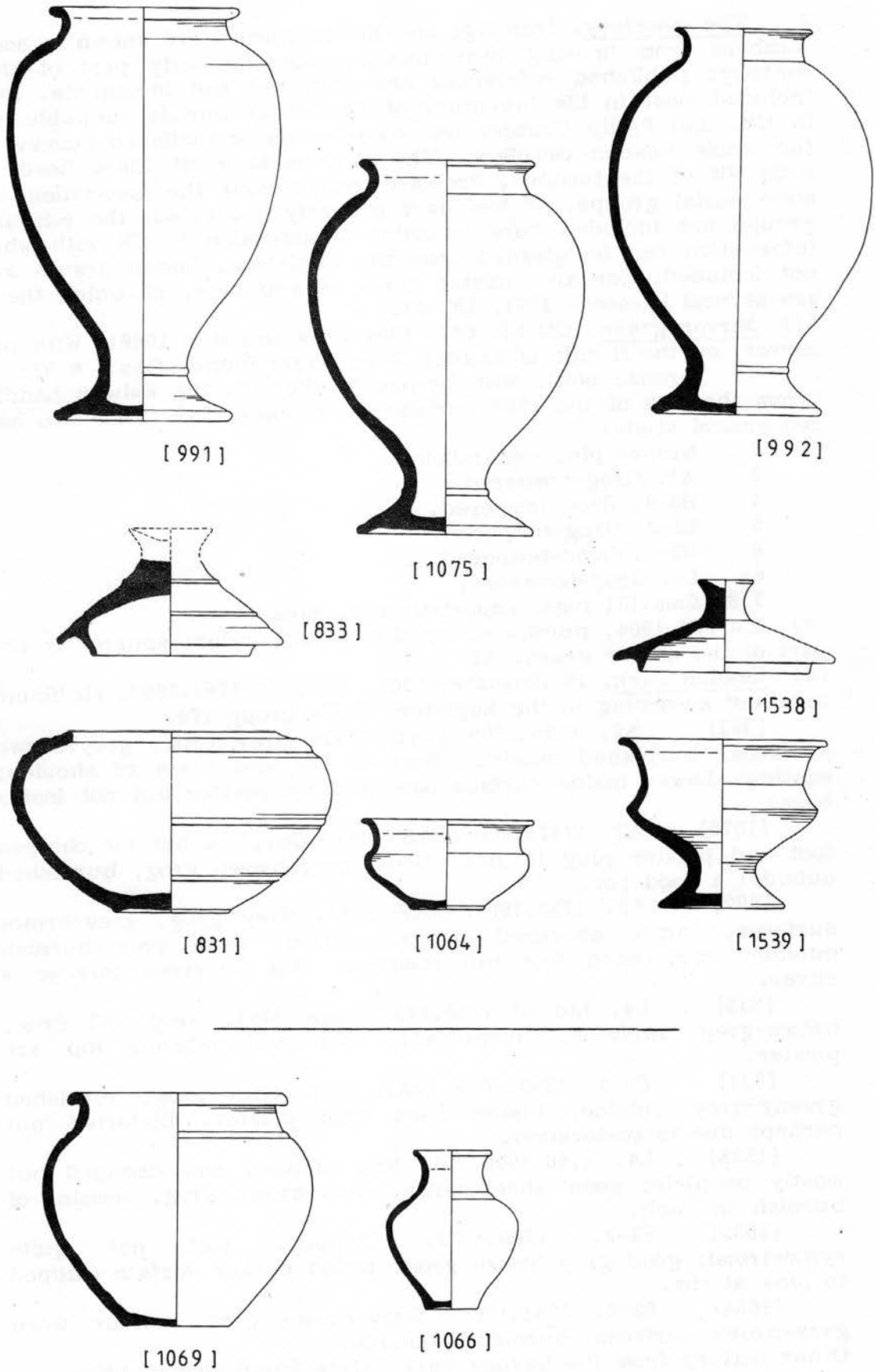
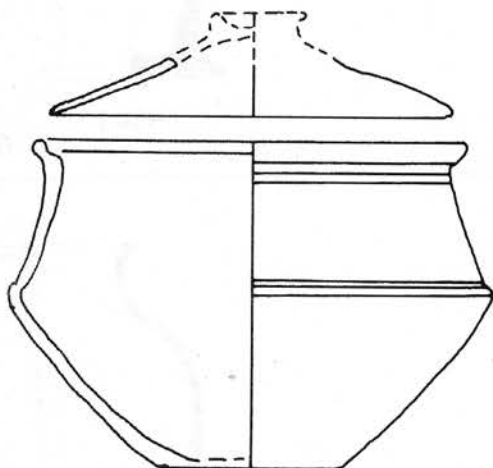

Fig.55: Pottery from Lexden, group 3. 1:4

[1069] B1-3. 1763.1909, 'with another pot of brown ware & a bottle of red ware, both fragmentary'. Roman, gritty, patchy rough buff-grey surfaces, no burnish; bones.

[1066] E3-6. 1762.1909. Roman, hard blue-grey core with small white grits, red below badly flaking pale grey outside, grey inside, not quite evenly shaped.

Also Roman is 1764, a grey Cam.120, found during laying of a water main. 1765 is AB 214, of shale, in only a few fragile pieces and not redrawn.



1766.1909: Hull's drawing. D2-1, L6. The Register reads: 'A number of fragmentary vessels found during excavations in Lexden Park, some of which are early Late Celtic, others of 1st cent. AD.' While 1756-1761 are described as found together it is quite uncertain how many burials are represented; they would appear, however, to be contemporaries.

(4) Mr V. Marshall's house: CM 2606.1912.

[1080] F3-1 (=AB 217). 'Found on site of donor's house in Lexden Park.' Very fine pot: leans slightly, restored but leaned when made. Grey fine grog, brown-grey surfaces, smooth inside, burnished outside.

An added note reads: 'Found with fragments of large cordoned pedestal Urn, 2606.12.' I have not identified this vessel, and its description is quite unlike 2623.1912, below.

[954] A1. 2623.1912 (=AB 184). Probably from Mr Marshall's garden. Grey grog, buff inside, patchy dark grey-brown outside, burnished. Restored; broken foot. Contains a few bones.

2607-8.1912 are the 'rim of Belgic grey ware patera... 1st cent. AD', and a bone pin, found 'on the site next door but one to Mr Marshall's nearest to Lexden Road'; these are likely to be Roman.

(5) Lexden Park, 1913: 'Nos.2719-2727 were found together with nos.2606 and 2623 on the W side of St Clare Road, Lexden Park Estate, during 1912-13' and later bought by the Museum through Philip Laver. It is not known how many burials are represented, and there are no valid associations.

[832] A2. 2719.1913 (=AB 185). Reddish-brown grog, dark grey surfaces, burnished outside, much restored inside.

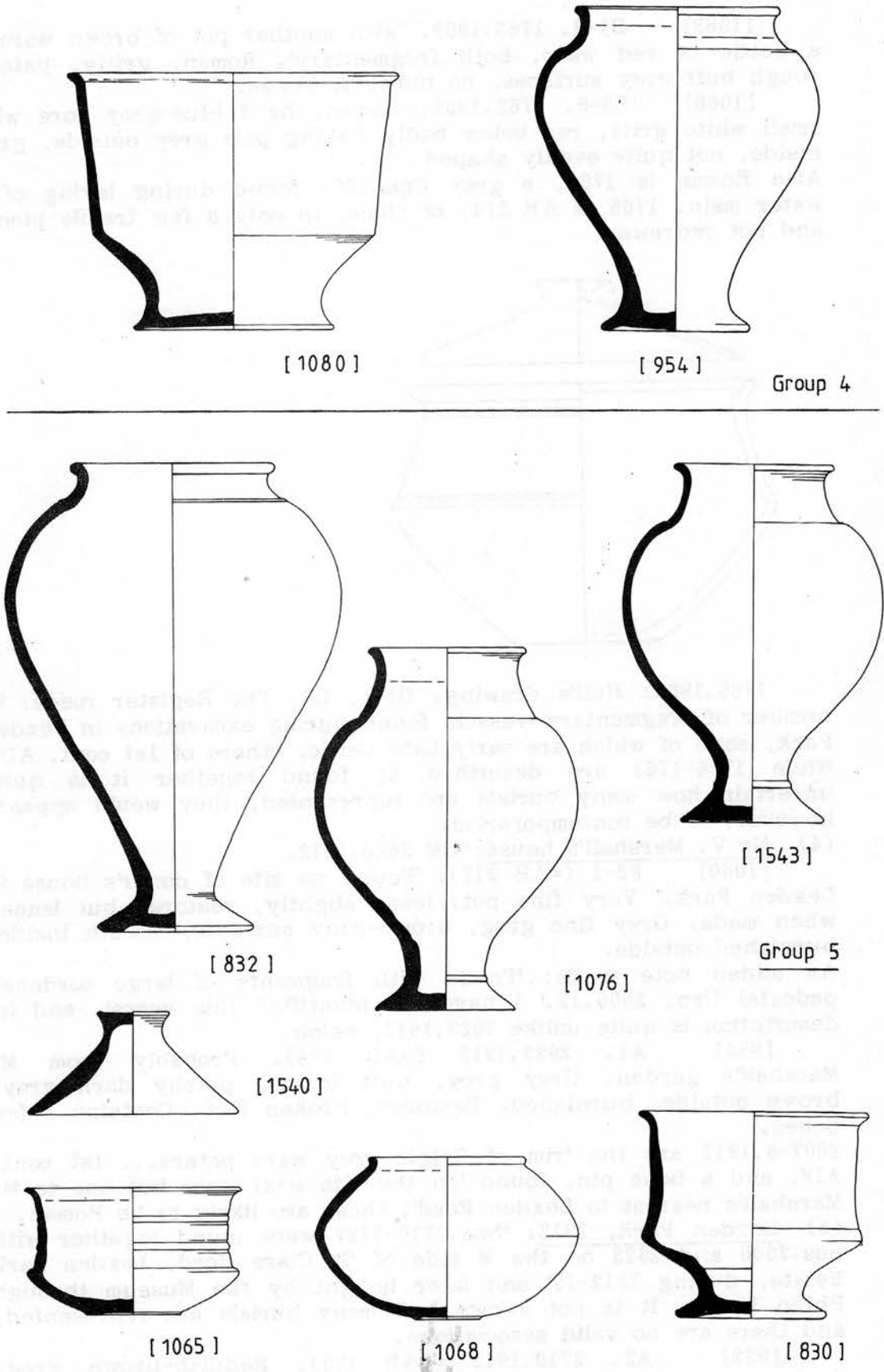

Fig.56: Pottery from Lexden, groups 4 and 5. 1:4

[1076] A2. 2720.1913. Hard grey grog, showing in chipped foot, patchy grey-buff surfaces, large grey firing patch outside, not as much burnish as usual. Very shallow cordon.

[1543] A2. 2721.1913 (=AB 187). Restored; grey-brown grog, darker grey surfaces, burnished all over outside.

[1540] L6. 2723.1913. 'Found close to Carinated bowl, no.2722 and probably belonging to it.' Good grey-brown grog, dark grey burnished surfaces; chipped, and some of rim restored.

[1065] E1-2. 2722.1913. Restored, brown-grey grog with buff below buff-grey worn inside, grey burnished outside.

[1068] B5-4. 2724.1913. Restored (half plaster): seems good usual grog, buff-grey inside, brown rim, dark grey burnished outside.

[830] F3-1. 2725.1913 (=AB 218). Soft grey grog, orange-brown below dark grey surfaces, burnished outside. Worn rim.

2726.1913: F3-2. Hull's drawing; shale, 'found with above vessels'.

2727.1913: A2. Hull's drawing; 'found with above'. Not found.

(6) CM 2861.1913.

[1541] F3-2. 'Model in turned Walnut Wood of a Late Celtic Tazza found in fragments at Lexden, 1912.' This has been assumed to be taken from a shale original; it does not appear to be a scaled-down model of the shale fragments, 2726.1913, above.

(7) Mr Marshall's garden, St Clare Road:

[1067] E3-6. 3419.1916. Roman, matt brown fabric with grey surfaces, worn to buff at inside rim.

3420.1916 reads: 'Body of Pot, neck and rim wanting of thin brown-red ware, dark brown exterior showing fine horizontal combing on sides, chamfered base. Found with No.3419. Late Celtic.'

(8) Mr Marshall's garden, 12 March 1920:

[1104] L5. 3964.1920. Very hard grey grog, dark grey surfaces, burnished outside: in pieces, much lost.

[1105] D3-4. 3964.1920. Same fabric as lid; nothing survives of lower half.

(9) Mr Marshall's garden, 1922. CMR 1923, 9, describes 4336.1922 as Lower half of a pot of brown ware with cordon round bulge. This has not been identified, or illustrated by Hull.

(10) Mr J. Harper's garden, St Clare Road, 1922. The Register divides the finds into three groups, although the associations should not be taken as complete. A note added later to 4310-4315 states 'These were all found in Mr Harper's garden, St Clare Road, 1922.'

i

[933] A2. 4311.1922 (=AB 175). Grey grog, grey-brown surfaces, very neatly made, smooth outside. Now broken; large part of shoulder and rim missing. Foot much restored and filled with plaster; reddish under foot. Contains a fair quantity of bones.

[1062] E1-2. 4312.1922 (=AB 177). Grey-brown fine grog, dark grey-brown surfaces, burnished outside and over rim, very shallow incised cordons.

[1063] E1-2. 4313.1922 (=AB 176). Almost but not quite identical to [1062]. These were 'found with above vase' [933].

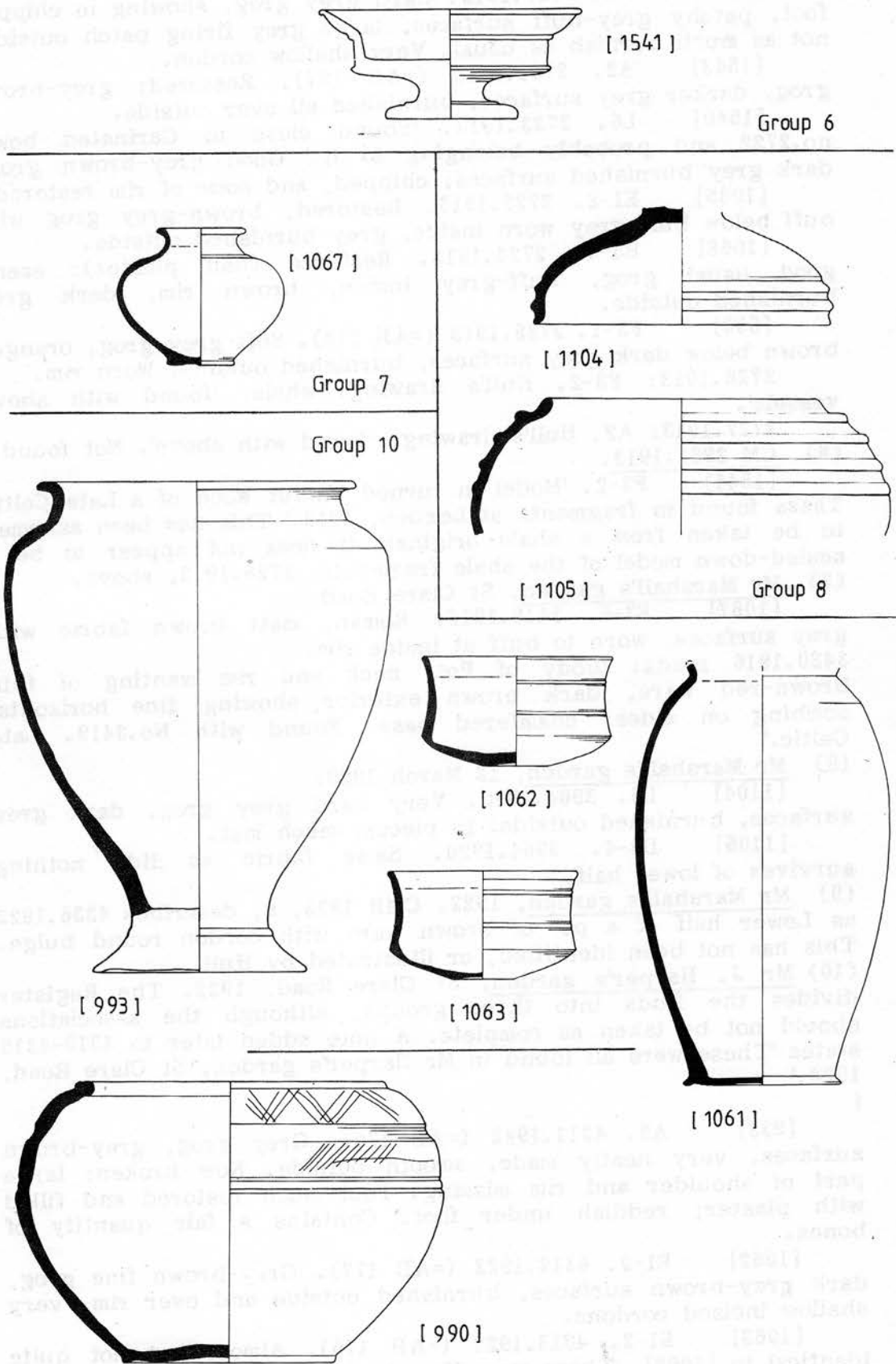

Fig.57: Pottery from Lexden, groups 6, 7, 8 and 10. 1:4

[1061] B5-2. 4310.1922 (=AB 174). Fine grey-brown grog, dark brown surfaces, burnish all over outside. Restored; fine pot. Contains bones.

ii

4314.1922: 'Remains of Flagon of buff ware with 3-ribbed handle... similar to Loeschcke's (Haltern) type 45 & Ritterling's (Hofheim) type 50B. Found with above. Late Celtic. 1st cent. BC.' This is AB 173, not redrawn here.

4315.1922: 'Remains of a bronze Pail or Tankard, the body of which may have been of wood or leather. Found with the above.'

iii

[990] D3-4. 4409.1923 (=AB 212). Grossly distorted in restoration; grey grog shows clearly on worn base. Fairly rough brown-grey surfaces, burnished outside, faint shallow incised decoration and rough horizontal tooling below cordon.

4410.1923 is the lid of 4409, form L1; despite repeated searches I have failed to find this in CM. According to the Register, it was not complete when found.

(11) Hull's burial no.205 has been published (Hull 1925-27): 4932.1924. The group consists of a Hofheim flagon, Cam.161; two butt-beakers, Cam.112A and 113; and a TN platter, Cam.8. They are all pre-conquest fine ware, imports except for the Cam.113.

(12) Mr Osmund Locke's garden, St Clare Road/Lexden Road, 1931. This group also consists of imports.

2056.1931, Cam.161 flagon.

2057.1931, TR cup.

2058.1931, Cam.185A amphora.

2059.1931, neck and handles of amphora with deep collar rim, i.e. Dressel 1, stamped HI[E?] (Peacock 1971, 184).

These were found 'quite near the ramparts', Lexden Dyke, just S of Lexden Road.

(13) Lexden Road, June 1936. 'Found in the garden immediately behind No.127 Lexden Road, at a depth of about 2 ft 6 ins'; 'obviously forming one grave group':

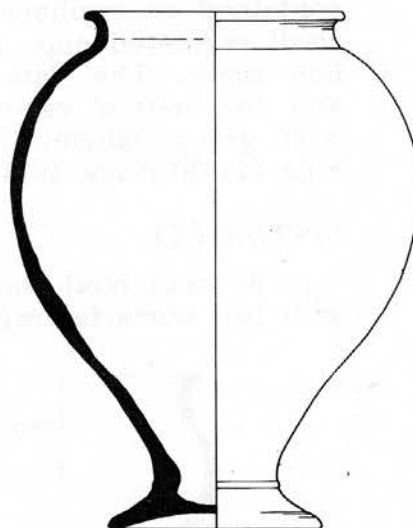
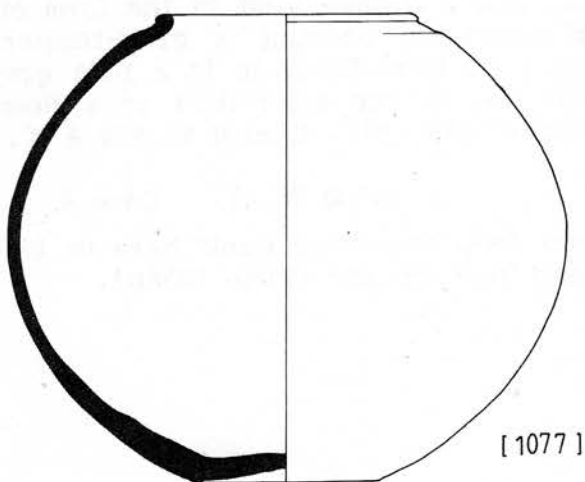

Fig.58: Pottery from Lexden, group 13. 1:4.

[1077] B5-4. 904.1936. Complete but worn. Grey coarse grog, grey patchy surfaces, much worn off inside; red-orange on rim and patches outside, burnished all over, very heavy. Contains bones.

[1078] A1. 905.1936. Grey grog, restored, grey-brown surfaces, reddish foot, some red on rim, burnished.

Hull's drawing: B3-7. Not found. The Register states 'all [are] in soft brown-black ware'.

(14) Mr Locke's garden, St Clare Road, 1940 (Hull 1942). This is another group consisting of imports and fine wares: a Drag.17 platter; Arretine Loeschke 8 cup; two TR cups, Cam.56; TR Cam.7 platter; two TN Cam.8 platters; TN Cam.12 platter; TR Cam.77 pedestalled beaker; Cam.113 butt-beaker; two Cam.161 flacons; a small blue glass bottle. The date is apparently just post-conquest.

The Lexden burials divide clearly into those without imports, but often with A2 pedestal urns, and those with imports; the second group is evidence of some wealth. I think there is little doubt that the importless graves are of a period when imported wares were unavailable, in the second half of the 1st century BC, although the metalwork and amphorae of rich early burials elsewhere are lacking.

LIMLOW HILL (C)

TL 323 418 Zone 8

An incomplete hill-fort on the edge of the Chilterns chalk scarp produced a 'late Belgic' sherd from the rapid silt of an enclosure ditch; from the drawing in Clark (1938) the piece is a scrap from a slashed-rim lid-seated jar of a type that is commonly shell-tempered and often post-conquest (see C5-2).

LINTON (C)

TL 556 464

A grave found in 1926 in a 'circular pit' dug into chalk contained an amphora, copies of Gallo-Belgic wares, a white jug, a small carinated cup, a brooch, and a bronze stud in the form of a lion mask. The date is post-conquest; nothing is grog-tempered and the 'native' carinated cup (cf. form E2-1) is in a pale grey-buff gritty fabric. The burial was in the same field as a Roman villa (Lethbridge 1928; Liversidge 1977, 27). CambM 26.494 A-K.

LINTON (K)

c.TQ 75 48 Zone 4

A small bowl was dredged from the river Beult here in 1958, with two mortaria fragments and 'half an olla' (Pirie 1958b).

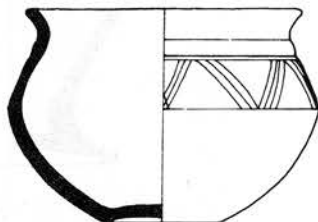

[244] E2-1. MM 34.1958. Coarse pale grey HM, apparently grog, restored, with tooled dark grey inside and patchy buff-dark grey outside. Well executed incised decoration.

Several uninscribed staters and quarter-staters, and a stater of Cunobelinus, are known from Linton (Payne 1895, li).

LITTLE HALLINGBURY (E)

TL 494 164 Zone 7

About 20 vessels were found in burial groups in 1876, in a gravel pit near the river at South House Farm (H. Laver 1905). Four survive today; evidently the rest suffered the fate Laver feared, of 'being smashed by the housemaid'.

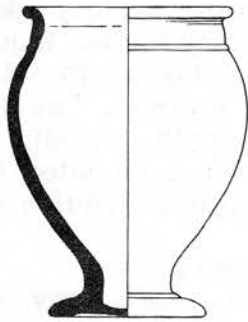

[1081] A1. CM 933.1905 (=AB 141). Hard grey-brown grog, pale brown surfaces, much lost inside, burnished outside, darker brown foot.

The other three vessels in Birchall (1965, nos.142-144) are behind glass in Little Hallingbury Church.

no.142 B2-4.

no.143 B3-6.

no.144 B3-5.

Of seven vessels in Laver's photograph, most are of recognisable form: from left to right,

1 (AB 142).

2 B5-3.

3 F2.

4 unknown.

5 B3-6.

6 (AB 143).

7 B5-1.

Lid ?L6.

The site is very near Wallbury Camp (q.v.). Earlier Iron Age settlement finds are known in the vicinity from work on the M11 route, but no 'Belgic' (Robertson 1976, 86-87).

LITTLE LAVER (E)

TL 5430 0915

1st and 4th century remains were found in a field N of Little Laver Mill in 1906 during drainage works, and in excavations by the Roman Essex Society in 1946 which found a ditch (W. Rodwell 1976c, 239-242; VCH 1963, 153).

1906: ChM B18001-5, 18008-9. Animal bones, a coin of Antoninus Pius, an iron knife, and two 4th century vessels were found as well as a large white ware butt-beaker and a small bowl (W. Rodwell 1976c, fig.2 nos.7 & 8):

7 not in series. B18001.

8 E3-1. B18002.

1946: ChM B18006-7. Rodwell (*op.cit.*, fig.2 nos.15-20) publishes a selection of pottery from the 1st century ditch, and describes as with them one flint-gritted sherd, 'various grog-tempered sherds of the Belgic Iron Age and sherds of vessels in

Roman or romanising fabrics of the mid and later 1st cent.' The pottery now in ChM does not appear to include any grog-tempered sherds. Those illustrated are either shell-tempered coarse wares or Roman: they include a Cam.28 platter. VCH (1963, 153) states that 'Iron Age A' pots were found in the ditch below the Roman, but this is not mentioned in the ChM slip files. They are presumably represented by the flint-gritted sherd.

LITTLE MUNDEN FARM (H)

TL 1385 1041 Zone 7

A limited excavation of a Roman pottery kiln in 1974 discovered the apparent site of the Lugdunum factory, making mortaria, jugs, etc., and dating to c.AD 55-75 (Saunders and Havercroft 1977). A little 'Belgic' pottery, evidently grog-tempered, was found with kiln types in both the kiln area and the enclosure ditches. 'Romanised' pottery is not included here.

no.208 B3-8. Kiln area. Grey-brown, reddish core, spalled surface.

no.213 C1-2. Kiln area. Dark grey.

no.230 C6-1. Ditch 3, layer 17. Soft grey core, patchy brown-orange surface.

no.253 B5-3. Ditch 4, layer 18. Dark grey, burnished.

no.254 D1-1. Ditch 4, layer 18. Grey, red-black soapy surface.

LITTLE WALTHAM (E)

TL 706 128 Zone 1

It is clear from the report on the excavations of the Iron Age village (Drury 1978) that grog-tempered pottery begins to appear at the end of the settlement sequence. Thin sections of the pottery designated fabric E as containing grog, 'with little quartz, which accounts for the soapy feel of the sherds in this group' (p.59). The incidence of fabric E is as follows:

Period II: single sherds from hut C3, features 87 and 96; some 10 sherds from hut C15: 'all probably intrusive'.

Period III: hut C1 (2 sherds), features 255 (no.266 + fragments), and 256 (no.286). Late 2nd-mid 1st centuries BC; enclosed settlement.

no.266 a small grooved sherd.

no.286 A8.

Period IV: one hut only was dated to this period, approximately the third quarter of the 1st century BC. Hut C5 (no.295); features 165 (no.301) and 232 (no.326). No.330, from site clearance, is also fabric E.

no.295 sherd only, 'like 286'.

no.301 large high-shouldered jar, like C2-1. This has a parallel at Heybridge (Drury 1978, fig.73 no.4).

no.326 C6-1.

no.330 sherd only, thick, with slight curve and rough grooving to make cordons.

The majority of the pottery is throughout of earlier Iron Age forms and fabrics: this evidence of overlap in technique is important. The forms of the grog-tempered vessels, where known, are not yet developed, but show the appearance of grooves and rippling and

indeed are incipient 'Belgic' vessels. Drury (p.133) compares them with those from Wederath in the middle Rhineland, where they date to the post-Caesarian period, c.50-10 BC. Wederath-Belginum provided parallels for the distinctive dotted decoration on no.301 (see Drury's fig.73). These parallels are used to date Period IV; earlier periods are dated approximately from radiocarbon samples and estimates of the life-span of timber buildings.

Various Roman finds with occasional grog-tempered sherds are known from this area but it is not known where the main 'Belgic' occupation may have been. The grave found near the Iron Age site dates to c.AD 50-60 (Drury 1978, nos.334-341): it contained two flagons, two butt-beakers, two platters and a cup, all Gallo-Belgic, and two very poor small native cups, one which crumbled to pieces and the other, lopsided, with a reddish core and soft black surface, not grog-tempered (no.341: E3-1). ChM.

LOCKLEYS (H)

TL 237 162 Zone 7

Ward-Perkins (1938d, 342-4) saw a progression from a crude circular native hut through a more substantial wood framed structure to the first villa, but argument has continued over the nature of the pre-villa occupation, which was not represented by good stratification (see W. Hughes 1938, 148; Rook 1972; Branigan 1973, 21-2).

It is not likely now to be resolved. We might observe that Ward-Perkins assigned nearly all his 'Belgic' pottery to the '2nd Belgic Level', and it is clear that these finds represent a span of some time, probably decades. I do not think, unlike Webster (in Rook 1972) that all the pre-villa occupation is post-conquest; but some of it undoubtedly is, since it includes samian and post-conquest brooches as well as native wares, platter copies, and butt-beakers. The stabbed and rilled jars, in particular, are similar to Wheathampstead types. The native pottery is predominantly developed in form, however, and must overlap the conquest.

Further study of the pottery is no longer possible as all the finds have disappeared except for nos.36 and 56, which are on display in LeM as 'Late Iron Age pottery'. The plan of the site (*Britannia* 2, 1971, 269) shows the boundary ditch; this has been sectioned but no finds are extant.

'1st Belgic house':

- 1 A1, hut floor.
- 2 C8-1, 'associated pit'.
- 3 A1, 'associated pit'.
- 4 C6-1, 'associated pit'.

In 'associated levels' were white jug sherds, 1st century AD.

'2nd Belgic occupation-level':

- 1-3 G5-6.
- 4,5 not in series. No.5 is an import.
- 6 G3-1.
- 7,8 G1-3.
- 9 G5-6.
- 10-11 butt-beaker scraps.

- 12 E1-2.
- 13-4 scraps.
- 15 C5-2.
- 16-8 scraps.
- 19 G1-1.
- 20 C8-1.
- 21 C7-1.
- 22-3 A1.
- 24-6 C8-1.
- 27-9 not in series. 28 and 29 are probably C6-1.
- 30-1 C7-1.
- 32-4 rippled and decorated shoulder sherds.
- 35 not in series.
- 36 in LeM. Post-conquest; very black shiny surface, no grog.
- 37 B1-1.
- 38 B3-2.
- 39 not in series. Could be G4 or G2-3.
- 40 Cam.136 jug (Tiberian onwards; AD 43-61 at Sheepen).
- 41 not in series.
- 42 B1-1.
- 43 uncertain form.
- 44 not in series.
- 45 C1-2.
- 46 A5.
- 47 D3-1.
- 48-9 not in series.
- 50 not in series. May be Cam.241.
- 51 D2-3.
- 52 E2-2.
- 53-5 not in series. No.55 at least is Roman.
- 56 in LeM. Hard reddish pale Roman fabric, no grog.
- 57 D3-2.

LONDON

London and its suburbs are still notably devoid of late Iron Age material, and the programme of excavations has so far failed to reveal any substantial body of grog-tempered pottery that can be dated much before the Flavian period (pers.comm. C. Green, 1980); in the City, 'there was no substantial pre-Roman occupation of the site' (Schofield and Dyson 1980, 6). The area is well away from the main distribution area of 'Belgic' pottery. Flints and possibly Claudian or late Iron Age sherds came from the GPO site in Newgate Street at TQ 3204 8135 (Britannia 7, 1976, 345; Hobley and Schofield 1977, 51-2) and an inhumation of uncertain date cut a pit with 'possible Iron Age' sherds on the site of the Tower, TQ 337 805 (London Archaeol. 3, 1977, 39; Schofield and Dyson 1980, 6). There are many 1st century amphorae in MusL, but not always of certain provenance (W. Rodwell 1976a, 324). In view of the finds from Southwark, below, and Marsh's recent proposition that the Arretine from 'London' is derived from 19th and 20th century dealers (Marsh 1979) 'Belgic' London may be ruled out, at least for the present.

In MusL, however, are two complete pots from Fetter Lane. They come from a collection made by John Allen of Saltford, near Bristol, and bought by the Guildhall Museum in 1914. They appear in the list of the Allen Collection (Roman and medieval pots found in the City in the 1890s) as follows:

2463 Roman jar, found in Fetter Lane, 1892...

2470 Saxon urn, found in Fetter Lane, 1892...

They were recognised as late Iron Age in 1930 and were the subject of articles by Quintin Waddington (Evening News Jan.26, 1937; Waddington 1934, 391 & fig.17); they appear in Ward-Perkins' discussion of 'South-Eastern B' jars (1938a, fig.10, nos.6, 7). There is no indication that they were found together, but as one was assumed to be Saxon they were separately catalogued. A search of the MusL files reveals no other pottery from Fetter Lane in 1892, but while bearing in mind the lack of circumstantial evidence, and the fact that one of the vessels at least was made in Kent, there is no indication that they were not in fact found in Fetter Lane.

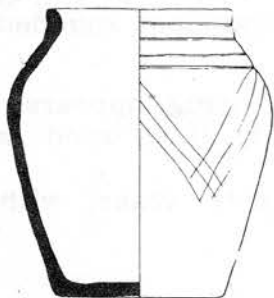

[776] B2-3. MusL 10461. HM grey greensand Medway Valley fabric, incised zig zags all round pot; larger pieces of grit causing surface flaws. Leans slightly; not a very good pot.

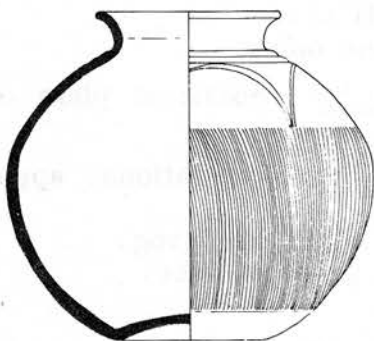

[777] S3. MusL 10454. Fine brown grog, pink sandwich at rim but not neck, buff surfaces, burnished around base and on neck and rim; fine shallow incised double standing arc, and rouletting. Very well made and finished; restored; small part of rim missing and worn at base. Inside estimated in drawing.

A pot in the Allen Collection found in Fetter Lane in 1894 is shown in Marsh and Tyers 1976, fig.12 no.2: MusL 10458. This is a small jug in a hard sandy grey fabric, 'probably from the Rhineland and probably Claudian'. On present evidence it would seem likely that the two 'Belgic' pots are post-conquest depositions. They are not locally-made vessels.

Southwark: grog tempering is used for a restricted range of forms found in the 1st and early 2nd century levels, after c.AD 50 and usually in coarse ill-defined forms. Mixtures of tempering also occur (Southwark 1978). The relevant types, as defined by Marsh and Tyers (in Southwark 1978, 533) are:

II A-1 (4 examples): neckless bead-rim jars, upright rim.
II A-2 (3 examples): neckless bead-rim jars, small, rolled out rim. (These are usually Flavian.)

II A-3 (one): like A-2 but much larger and heavier.

II A-4 (two): neckless bead-rim jars, very large internal thickening.

II A-8 (one): neckless bead-rim jars, larger with bead flat on top; thick body wall above and thin below.

II L (three): 'large storage jars', including Patch Grove wares.

II N (one): pre- and early Flavian necked jar with high shoulder. Usually sandy.

IV F2 (one): IV 2 is a restricted, perhaps local, type of bowl, changing from grog to sand temper in Highgate phase III, early 2nd century. F2 has a short downbent rounded rim.

Grog-tempered vessels:

(i) 201-211 Borough High St: grog appears occasionally in pre-Flavian levels. Except for no.40 it is used only for coarse wares.

no.40 D2-1. This is the only vessel with a good pre-conquest form.

no.55 L9.

no.82 C1-2 (II A-2).

no.131-2 C1-4 (II A-3; II A-2).

no.135 C1-2 (II A-8).

no.74 C6-1. This has shell as well as grog.

From Trajanic-Hadrianic levels:

no.187 storage jar rim (II L).

no.233 C1-2 (II A-4). One only.

(ii) 106-114 Borough High St: occasional plain coarse bead-rims with some grog.

(iii) 96-104 Borough High St: observations, apparently pre-Flavian:

no.590 platter base, HM with some grog.

no.591 small HM stunted pedestal base.

(iv) Bonded Warehouse:

no.601 C1-2 (II A-1), pre-Flavian.

no.752 B1-7. Pre- to early Flavian occupation SE of road.

no.652 C6-1 (II L) Flavian.

no.826 F5. Flavian.

no.665 C1-4 (II A-4). Flavian.

no.666-7 C1-2 (II A-1, II A-2). Flavian.

no.680 G2-3 (IV F-1). Flavian. One of the few instances of grog used for a finer type, but mixed.

no.736 G2-3 (IV F-4). Flavian.

no.741 L9. Flavian.

no.781 L9. Flavian.

no.735 D1-4. Flavian, and HM.

(v) 1-7 St Thomas St:

- no.856 B1-1 (II N). Mid-late 1st century.
no.865-6 C1-2 (II A-1). Mid-late 1st century.
no.970 S2. In early 2nd century levels.
no.1002 C7-1 (II L). Late 1st-early 2nd century.

(vi) 93-95 Borough High St, Flavian-Trajanic levels:

- no.1421 G2-2 (IV F-2). Highgate type.

LONG MELFORD (S)

TL 862 454 & area

Much Roman settlement evidence is known (Smedley 1961), mostly from observation of building works and small trial trenches, and chance finds. There is a good deal of early Roman with romanising 'Belgic' forms; a search in IpM did not reveal any grog-tempering. See Smedley's sites 1, 4, 10, 16, 18, 36 and 42.

fig.45a E1-2. Site 4; 'red polished ware'.

fig.45b (C7-1). Site 4. Probably Roman. Site 4 also has hard grey romanising 'Belgic' types.

fig.45c (C6-1), but this variety often occurs in Roman fabrics.

fig.45h B3-1, 'Romanising Belgic ware', site 19, with a Drag.30 and storage jars.

LOOSE (K)

TQ 765 515 Zone 4/5

The defensive earthwork known as Quarry Wood Camp has been claimed to be of some importance (W. Rodwell 1976a, 334) but only large-scale investigation would make its nature and purpose more clear. Prior to limited excavation of sections through the defences the only known finds from the Camp were from 2 pits on the N side, found in 1911: these are very mixed, and include a Dressel I amphora and a La Tene II type brooch as well as Roman sherds. The Kent Archaeological Society investigations, 1963-67, did not recover much, and the date of the defences remains uncertain (Kelly 1971; Champion 1976, 60-61, 123). The site is undoubtedly of potential importance, since it is in an area of intensive late Iron Age occupation and has traces of an extensive dyke system.

1911: at least three different traditions are represented, local Iron Age, 'Belgic' and Roman.

1 not in series. HM, like most of these, very hard grey, full of large grits, roughly burnished.

2 not in series. Thick hard heavy grey gritty, dark grey burnished surfaces.

3 B2-2. Dark grey, HM, thick, white grits, dark grey-brown surfaces, burnished outside and over rim.

4 B2-2. HM, dark grey, white grits, burnished outside.

5 B2-2. Grey greensand, dark grey surfaces, burnished outside and over rim, shaped with shallow tooling.

6 B2-2. Grey greensand, pale reddish surfaces, smoothed.

7 B2-2. Dark grey greensand, HM with deep grooves, irregular, burnish outside and fine combing below.

8 not in series. Hard grey HM, gritty.

9 not in series. Regular and perhaps wheel-made, dark grey very gritty ware with grey-buff surfaces, burnished outside, shallow incised decoration.

10 not in series. Grey greensand, HM, fine combing (C1-2).

11 not in series. Dark grey, white grits, rough, HM, burnished rim and shallow combing.

12 not in series. Hardly any bead at all; hard gritty grey, shiny brown surfaces.

13 B1-1. Wheel made, hard grey granular fabric with some grog and grits, grey surfaces, burnished outside.

14 not in series. Rough dark grey, no grog, burnished decoration.

15 B3-1. Thin brown fabric, unlike the others but no grog; grey surfaces, burnished dark outside.

16 sherd, slightly gritty, grey core, brown-grey surfaces, burnished grooves and lines on outside, wheel-made; an attempt on inside to drill hole to make a spindlewhorl, 0.5 cm deep.

17 not in series. HM, flint-gritted, brown surfaces, grey core.

18 not in series. Very summary HM irregular pot, grey greensand, rough tooling all over outside and over rim. (C2-3).

19 (G5-4). Pale brown greensand, not combed but smoothed.

20 B1-1. Wheel made, hard grey grog, worn brown-grey inside and burnished dark grey outside.

21 (A10). Very different: wheel-made Roman, hard pale grey-brown with white inclusions, pale grey surfaces, burnished heavily.

22 D3-1. Hard, wheel-made, grey core with black and white grits, paler grey surfaces, burnished outside.

23-5 hard grey Roman sherds.

26 sherd, dark grey grog, pale red burnished outside, faint burnish lines.

27 sherd, hard grey, probably Roman, light burnished lines.

28 not seen.

29 sherd, HM, pale brown-grey with lumpy core and pale inclusions, soapy, rough stabbing lines.

30 sherd, sandy grey, very shallow combing.

31 hard grey greensand, patchy grey-buff surfaces, shallow regular tooling.

32 Cam.113 cream fabric butt-beaker rim.

33 amphora sherds, much more extant than the stamp, which is 'almost certainly of Dressel I' (Peacock 1971, 182).

34 hard sandy brown-grey spindlewhorl made from sherd; could be Roman.

35 La Tene II derived brooch, a 1st century BC type.

1963-67: these are worn Iron Age/'Belgic' scraps only, and include a flint-gritted Iron Age base, no.6, found with nos.1-5 and 8 in the bank; and sherds from a Roman Black Burnished jar, no.7, from the E ditch.

It is very clear that there is little grog-tempering from the site; the fine greensand ware, however, is a local fabric that is

contemporary with grog for 'Belgic' forms, and flint gritting overlaps the use of grog at other sites, notably Borden (q.v.).

The discovery marked 'Belgic pottery 1970' on Kelly's plan of the area of the Camp, at TQ 782 516, is also now in MM and consists of several hard, regular, everted rims in a dark grey flint-gritted fabric, one or two flat bases, and a single odd grog-tempered rim:

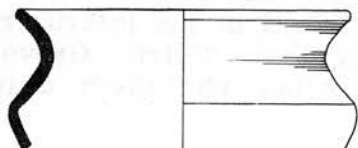

[1176] D1-2. Furfield Hole, 1970. Very hard pale grey grog with reddish rough surfaces. The pottery was apparently redeposited, and found with Roman material at the quarry face (Kelly 1971, 72). All in MM.

LOWER HALSTOW (K)

TQ 860 675 Zone 5

A collection of sherds found with briquetage near the church was presented to the BM in 1930: it was evidently from a saltworks on the N Kent marshes (Burchell 1925; 1927; Miles 1975, 28-30). Like other local sites the pottery is a mixture of Iron Age and 'Belgic' forms but the tempering is of coarse flint grit, not grog. Some Roman sherds are also present.

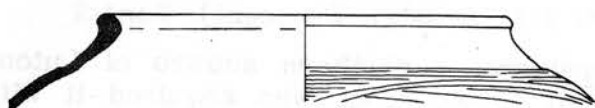

[40]

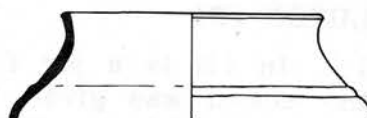

[37]

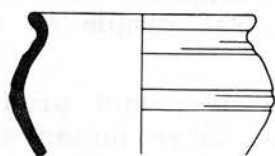

[38]

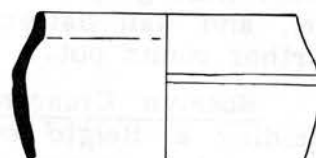

[39]

[40] not in series. Hard grey, very large grits, pinkish inside.

[37] B1-4. Hard HM black gritty, white grits, pale red surfaces, blackish patches on outside.

[38] E3-3. Hard grey gritty, black surfaces, burnished outside. A probably post-conquest form.

[39] Hard black HM Iron Age fabric, burnished outside. Other sherds have rough scoring on the surface; one piece is very like a combed C4 jar of the E Kent type. A sherd with incised circles is also present; Elsdon (1975, fig.14 no.18) illustrates another, in MM, found on the foreshore at TQ 867 680. Sherds found on the marshes with briquetage at TQ 864 676 are shown by Burchell (1927, pls.I & II). These are apparently now in IpM, and are at least partly HM and flint-gritted, but include some 'Belgic' forms.

LULLINGSTONE (K)

TQ 529 651 Zone 3

Some late 'Belgic' material was found under the villa,
 (i) unstratified, in the foundation trenches of the earliest villa walls, of c.AD 80-90;
 (ii) in a ditch under the NW corner of the granary (Meates 1955, 60); Meates supposes this may have been the boundary of an Iron Age settlement N of the villa. The ditch had Neronian samian in its primary silt. Two class II potin coins are also known (Meates 1979, 19-20 & 119). Various sherds are published in the interim reports, found beneath the villa; grog-tempered 'Patch Grove ware' continues into late 2nd century deposits. The ditch material is unpublished.

Meates, Greenfield & Birchenough 1950, fig.5:

1 (C1-2). This is on site, restored, a hard lumpy local fabric and apparently not grog-tempered.

7-9 B3-7. These are with the DoE, and from their strong resemblance to 'Patch Grove ware' jars are probably grog-tempered.

3rd interim, Meates 1953, fig.5:

120 L1. Period I occupation level, N complex. Also a plain Nauheim derivative iron brooch, and early Roman wares.

Local Iron Age wares from hut sites in the area in Lullingstone Park are as yet unpublished; one site at TQ 5235 6498 is reported to have produced some 'Belgic' pottery (Horner 1969).

LUTON (B)

TL 089 241 (Rosslyn Crescent) Zone 7

1 In LM is a jar from Limbury, a northern suburb of Luton; the vessel was given by a Mr Steele Elliot who acquired it with part of Worthington Smith's collection.

[838] D1-1. LM 345/40, WGS 3518. Hard brown, with grog, pale grey smooth unburnished surfaces. Blob of clay under rim, and wall flattened in large irregular dimple on widest part, further round pot.

2 Rosslyn Crescent is also in Limbury, and produced during building a 'Belgic' cemetery and much later Roman settlement. 5 pots and a pennanular brooch are on display in LM; others are known to have come to the museum from the Manshead Archaeological Society, but cannot be found. All the vessels are grog-tempered. 5 cremation vessels were found by the builders and sent to the museum. Subsequent excavations found 4 burial groups, on a small gravel knoll above the river Lea flood plain (Tufnell 1963).

(i) 2 pots, damaged. Bones in flat base; the other pot was like the group (iv) urn.

(ii) 2 pots and a burnt Colchester brooch, straight bow and perforated catchplate. One pot is on display; the other is of type B2-3.

[840] A1. LM 42/51/65. Grey grog, pink below patchy smooth grey-buff surfaces.

(iii) 3 pots and a Colchester brooch with perforated catchplate. Only one pot is now accessible; the others are of types A8 and E3-5.

Fig.59: Pottery from Luton. 1:4. Those vessels without solid section are scaled down from Tufnell 1963.

Limbury [838]

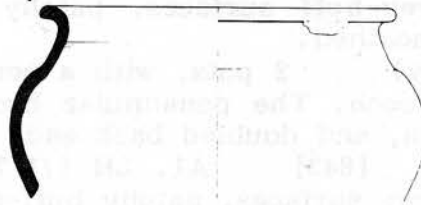

Rosslyn Crescent

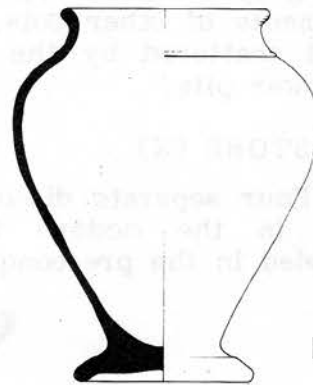
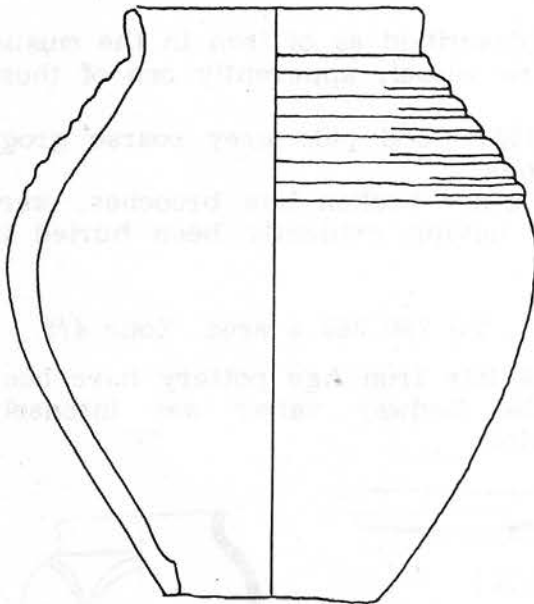

[840]

Grave 2

Grave 3

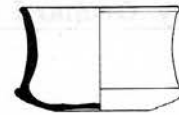
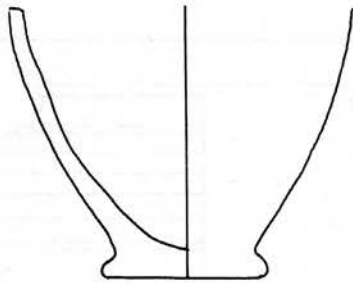

[841]

Grave 4

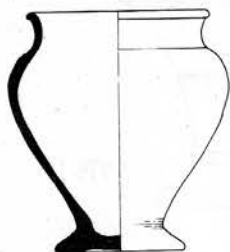

[843]



[842]

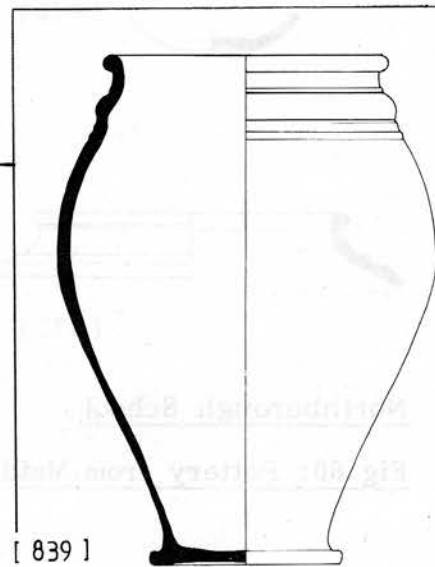

[839]

[841] E1-4. LM 2/51/65. Hard gritty grey grog, grey-buff surfaces, patchy outside, rather rough to touch but smoothed.

(iv) 2 pots, with a penannular brooch and a plain Colchester brooch. The penannular brooch, LM 38/51/65, is of bronze, with pin, and doubled back ends (Fowler 1960, type C).

[843] A1. LM 1/177/64. Grey grog, slightly gritty, dark grey surfaces, patchy buff-grey outside.

[842] B3-5. LM 2/1/62. Grey grog, slightly gritty, dark grey surfaces, buff patches outside; thick and heavy, smooth slightly irregular rim.

The Colchester brooches are all described as of iron in the musum Register. Also in LM is one extra vessel, apparently one of those found by the builders:

[839] B3-6. LM I, 1/2/62. Good pale grey coarse grog, dark grey surfaces. Contains bones.

Fragments of other pots, and 3 other broken bow brooches, were found scattered by the plough, having evidently been buried in shallower pits.